

HIGH-VOLTAGE MIXED-SIGNAL IC

UC8151

All-in-one driver IC w/ Timing Controller for
White/Black/Red Dot-Matrix Micro-Cup ESL

**Preliminary Specifications
Datasheet Revision: 0.1**

**IC Version: c_A
June 3, 2014**

ULTRACHIP

The Coolest EPD Driver, Ever!

Specifications and information herein are subject to change without notice.

Table of Content

INTRODUCTION	3
MAIN APPLICATIONS.....	3
FEATURE HIGHLIGHTS	3
BLOCK DIAGRAM.....	4
ORDERING INFORMATION	5
PIN DESCRIPTION	6
COMMAND TABLE.....	8
COMMAND DESCRIPTION.....	11
HOST INTERFACES	27
POWER MANAGEMENT.....	28
ABSOLUTE MAXIMUM RATINGS	33
DC CHARACTERISTICS	34
AC CHARACTERISTICS	36
PHYSICAL DIMENSIONS.....	38
ALIGNMENT MARK INFORMATION	39
PAD COORDINATES	40
TRAY INFORMATION.....	47
REVISION HISTORY	48

UC8151

All-in-one driver IC with Timing Controller for White/Black/Red Dot-Matrix Micro-Cup ESL

INTRODUCTION

This driver is an all-in-one driver with timing controller for ESL. Its output is of 1-bit white/black and 1-bit red resolution per pixel. The timing controller provides control signals for the source driver and gate drivers.

The DC-DC controller allows it to generate the source output voltage VDH/VDL ($\pm 2.4V \sim \pm 11V$). The chip also includes an output buffer for the supply of the COM electrode (VCOMAC or VCOMDC). The system is configurable through a 3-wire/4-wire (SPI) serial interface.

MAIN APPLICATIONS

- E-tag application

FEATURE HIGHLIGHTS

- System-on-chip (SOC) for ESL
- Timing controller supports several all-resolutions
- Resolution:
 - Up to 160 source x 296 gate resolution + 1 border + 1 Vcom
 - 1 bit for white/black and 1 bit for red per pixel
- Cascade: Up to 2 chip cascade mode
- Memory (Max.): 160 x 296 x 2 bits SRAM
- 3-wire/4-wire (SPI) serial interface

- Clock rate up to 20MHz
- Temperature sensor:
 - On-Chip: $-25 \sim 50^{\circ}\text{C} \pm 2.0^{\circ}\text{C}$ / 8-bit status
 - Off-Chip: $-55 \sim 125^{\circ}\text{C} \pm 2.0^{\circ}\text{C}$ / 11-bit status ($1^{\circ}\text{C}/\text{LM75}$)
- Support LPD, Low Power Detection ($V_{DD} < 2.5V$)
- OSC / PLL: On-chip RC oscillator ($1.625\text{MHz} \pm 5\%$)
- Vcom:
 - AC-Vcom / DC-Vcom (by LUT)
 - Support Vcom sensing (6-bit digital status)
- Charge Pump: On-chip booster and regulator:
 - VGH: +16V
 - VGL: -16V
 - VDH: +2.4 ~ +11.0V (programmable, black/white)
 - VDL: -2.4 ~ -11.0V (programmable, black/white)
 - VDHR: +2.4 ~ +11.0V (programmable, red)
- Digital supply voltage: 2.3~ 3.6V
- OTP: 4K-byte OTP for LUT
- Package: (TBD)
- COM/SEG bump information
 - Bump pitch: 26 μM
 - Bump gap: 14 $\mu\text{M} \pm 3\mu\text{M}$
 - Bump surface: 1200 μM^2

BLOCK DIAGRAM

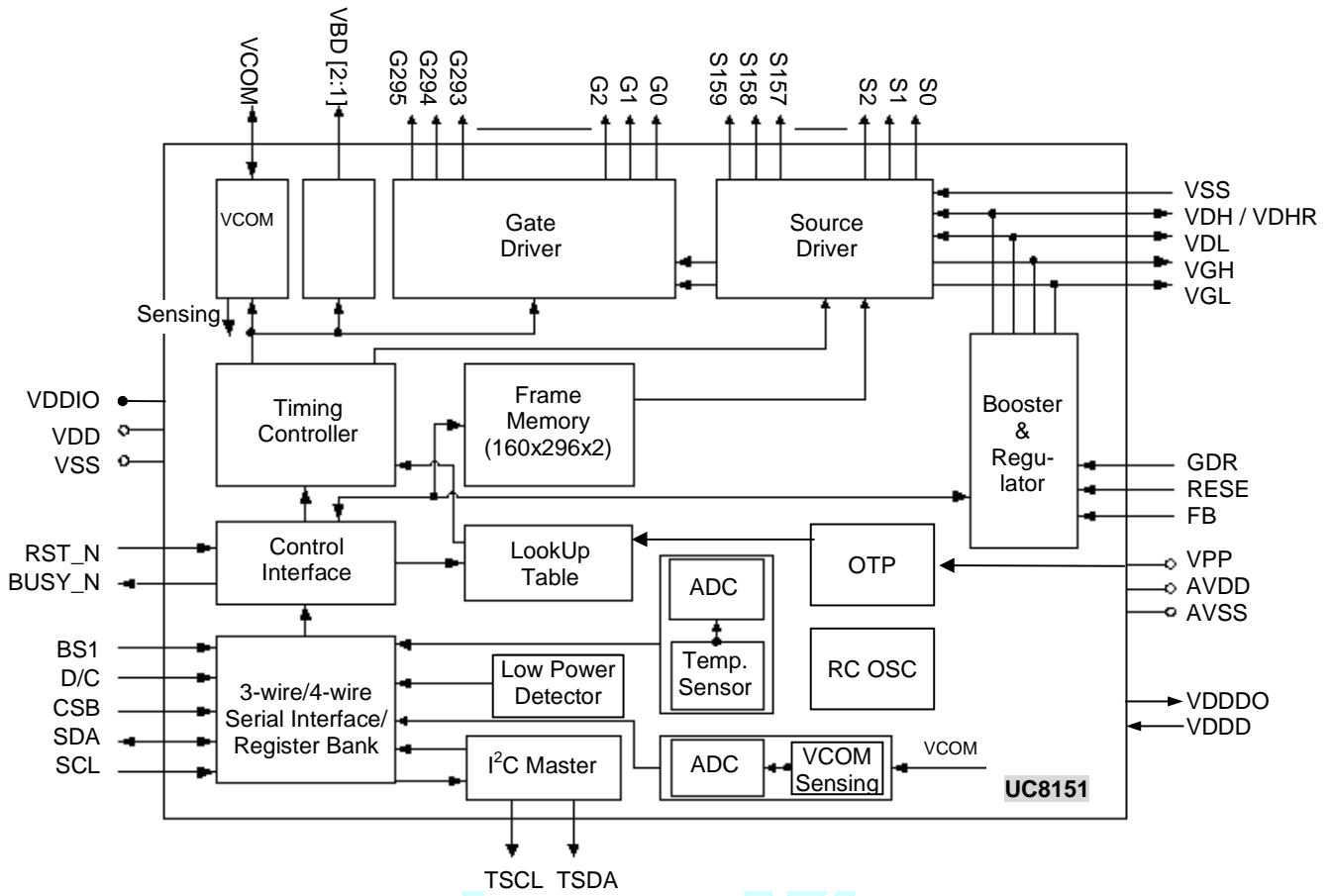

*Preliminary
Confidential*

ORDERING INFORMATION

Part Number	I ² C	Description
UC8151cGAA-U0P		COG

General Notes**APPLICATION INFORMATION**

For improved readability, the specification contains many application data points. When application information is given, it is advisory and does not form part of the specification for the device.

BARE DIE DISCLAIMER

All die are tested and are guaranteed to comply with all data sheet limits up to the point of wafer sawing. There is no post waffle saw/pack testing performed on individual die. Although the latest modern processes are utilized for wafer sawing and die pick-&-place into waffle pack carriers, UltraChip has no control of third party procedures in the handling, packing or assembly of the die. Accordingly, it is the responsibility of the customer to test and qualify their application in which the die is to be used. UltraChip assumes no liability for device functionality or performance of the die or systems after handling, packing or assembly of the die.

LIFE SUPPORT APPLICATIONS

These devices are not designed for use in life support appliances, or systems where malfunction of these products can reasonably be expected to result in personal injuries. Customer using or selling these products for use in such applications do so at their own risk.

CONTENT DISCLAIMER

UltraChip believes the information contained in this document to be accurate and reliable. However, it is subject to change without notice. No responsibility is assumed by UltraChip for its use, nor for infringement of patents or other rights of third parties. No part of this publication may be reproduced, or transmitted in any form or by any means without the prior consent of UltraChip Inc. UltraChip's terms and conditions of sale apply at all times.

CONTACT DETAILS

UltraChip Inc. (Headquarter)
4F, No. 618, Recom Road,
Neihu District, Taipei 114,
Taiwan, R. O. C.

Tel: +886 (2) 8797-8947
Fax: +886 (2) 8797-8910
Sales e-mail: sales@ultrachip.com
Web site: <http://www.ultrachip.com>

PIN DESCRIPTION

Type: I: Input, O: Output, I/O: Input/Output, PWR: Power, C: Capacitor pin

Pin (Pad) Name	Pin Count	Type	Description
POWER SUPPLY PINS			
VDD	7	PWR	Digital power
AVDD (VDDA)	10	PWR	Analog power
VDDIO	10	PWR	IO power
VDDDO	4	PWR	Digital power output (1.8V)
VDDD	4	PWR	Digital power input (1.8V)
VPP	6	PWR	OTP program power (7.75V)
VDM	4	PWR	Analog Ground.
GND	18	PWR	Digital Ground.
GNDA	17	PWR	Analog Ground
LDO PINS			
VDH (VSH)	10	I/O	Positive source driver Voltage (+2.4V ~ +11V)
VDHR	8	I/O	Positive source driver voltage for Red (+2.4V ~ +11V)
VDL (VSL)	10	I/O	Negative source driver voltage (-2.4V ~ -11V)
CONTROL INTERFACE PINS			
BS	1	I	Bus Selection. Select 3-wire / 4-wire SPI interface L: 4-wire interface. H: 3-wire interface. (Default)
RST_N	1	I (Pull-up)	Global reset pin. Low: reset. When RST_N become low, driver will reset. All registers will be reset to their default value, and all driver functions will be disabled. SD output and VCOM will be based on its previous condition; and may have two conditions: 0V or floating.
MS	1	I	Cascade setting pin. L: Slave chip. H: Master chip.
CL	1	I/O	Clock input/output pin. Master: Clock input. Slave: Clock output.
BUSY_N	1	O	Driver busy flag. L: Driver is Busy. H: Host side can send command/data to driver.
MCU INTERFACE (SPI) PINS			
CSB	1	I	Serial communication chip select.
SDA	1	I/O	Serial communication data input/output
SCL	1	I	Serial communication clock input.
DC	1	I	Command/Data input. L: command H: data
I²C INTERFACE			
TSCL	2	O (open-drain)	I ² C clock (External pull-up resistor is necessary.)
TSDA	2	I/O (open-drain)	I ² C data (External pull-up resistor is necessary.)

Pin (Pad) Name	Pin Count	Type	Description
OUTPUT PINS			
S0~S159 (S<0>~S<159>)	160	O	Source driver output signals.
G[0..295] (G<0>~G<295>)	296	O	Gate driver output signals.
VCOM	16	O	VCOM output.
VBD (VBD<1>~VBD<2>)	2	O	Border output pins.
BOOSTER PINS			
GDR	8	O	N-MOS gate control
RESE	2	P	Current sense input for control loop.
FB	2	P	(Keep Open.)
VGH	12	I/O	Positive Gate voltage.
VGL	16	I/O	Negative Gate voltage.
RESERVED PINS			
TEST1~TEST3	3	I	UltraChip reserved. Leave it floating or connected to VSS.
TESTVDD	1	I	UltraChip reserved. Leave it floating or connected to VSS.
TEST4~TEST7	4	O	UltraChip reserved. Leave it floating.
DUMMY	15	-	UltraChip reserved. Leave it floating.
NC	32	--	Not Connected.

Preliminary Confidential

COMMAND TABLE

W/R: 0: Write Cycle 1: Read Cycle C/D: 0: Command / 1: Data D7~D0: -: Don't Care #: Valid Data

#	Command	W/R	C/D	D7	D6	D5	D4	D3	D2	D1	D0	Registers	Default	
1	Panel Setting (PSR)	0	0	0	0	0	0	0	0	0	0		00h	
		0	1	#	#	#	#	#	#	#	#	#	RES[1:0],REG,KW/R,UD,SHL,SHD_N,RST_N	0Fh
2	Power Setting (PWR)	0	0	0	0	0	0	0	0	0	1		01h	
		0	1	--	--	--	--	--	--	#	#		VDS_EN, VDG_EN	03h
		0	1	--	--	--	--	--	#	#	#	#	VCOM_HV, VGHL_LV[1:0]	00h
		0	1	--	--	#	#	#	#	#	#	#	VDH[5:0]	26h
		0	1	--	--	#	#	#	#	#	#	#	VDL[5:0]	26h
0	1	--	--	#	#	#	#	#	#	#	VDHR[5:0]	03h		
3	Power OFF (POF)	0	0	0	0	0	0	0	0	1	0		02h	
4	Power OFF Sequence Setting (PFS)	0	0	0	0	0	0	0	0	1	1		03h	
		0	1	--	--	#	#	--	--	--	--		T_VDS_OF	00h
5	Power ON (PON)	0	0	0	0	0	0	0	1	0	0		04h	
6	Power ON Measure (PMES)	0	0	0	0	0	0	0	1	0	1		05h	
7	Booster Soft Start (BTST)	0	0	0	0	0	0	0	1	1	0		06h	
		0	1	#	#	#	#	#	#	#	#		BT_PHA[7:0]	17h
		0	1	#	#	#	#	#	#	#	#		BT_PHB[7:0]	17h
		0	1	--	--	#	#	#	#	#	#		BT_PHC[5:0]	17h
8	Deep sleep (DSLSP)	0	0	0	0	0	0	0	1	1	1		07h	
		0	1	1	0	1	0	0	1	0	1		Check code	A5h
9	Display Start Transmission 1 (DTM1, White/Black Data) (x-byte command)	0	0	0	0	0	1	0	0	0	0	B/W Pixel Data (160X296):	10h	
		0	1	#	#	#	#	#	#	#	#	KPXL[1:8]	00h	
		0	1	:	:	:	:	:	:	:	:	:	:	:
		0	1	#	#	#	#	#	#	#	#	#	KPXL[n-1:n]	00h
10	Data Stop (DSP)	0	0	0	0	0	1	0	0	0	1		11h	
		1	1	#	--	--	--	--	--	--	--	--		00h
11	Display Refresh (DRF)	0	0	0	0	0	1	0	0	1	0		12h	
12	Display Start transmission 2 (DTM2, Red Data) (x-byte command)	0	0	0	0	0	1	0	0	1	1	Red Pixel Data (160X296):	13h	
		0	1	#	#	#	#	#	#	#	#	RPXL[1:8]	00h	
		0	1	:	:	:	:	:	:	:	:	:	:	:
		0	1	#	#	#	#	#	#	#	#	#	RPXL[n-1:n]	00h
13	VCOM LUT (LUTC) (45-byte command, bytes 2~7 repeated 7 times)	0	0	0	0	1	0	0	0	0	0		20h	
		0	1	#	#	#	#	#	#	#	#	#	00h	
		0	1	:	:	:	:	:	:	:	:	:	00h	
		0	1	:	:	:	:	:	:	:	:	:	00h	
		0	1	:	:	:	:	:	:	:	:	:	00h	
		0	1	:	:	:	:	:	:	:	:	:	00h	
		0	1	#	#	#	#	#	#	#	#	#	00h	
		0	1	--	#	#	#	#	#	#	#	#	ST_XON[6:0]	00h
0	1	--	#	#	#	#	#	#	#	#	ST_CHV[6:0]	00h		

#	Command	W/R	C/D	D7	D6	D5	D4	D3	D2	D1	D0	Registers	Default	
14	W2W LUT (LUTWW) (42-byte command, bytes 2~7 repeated 7 times)	0	0	0	0	1	0	0	0	0	1		21h	
		0	1	#	#	#	#	#	#	#	#		00h	
		0	1	:	:	:	:	:	:	:	:		00h	
		0	1	:	:	:	:	:	:	:	:		00h	
		0	1	:	:	:	:	:	:	:	:		00h	
		0	1	#	#	#	#	#	#	#	#		00h	
15	B2W LUT (LUTBW / LUTR) (42-byte command, bytes 2~7 repeated 7 times)	0	0	0	0	1	0	0	0	1	0		22h	
		0	1	#	#	#	#	#	#	#	#		00h	
		0	1	:	:	:	:	:	:	:	:		00h	
		0	1	:	:	:	:	:	:	:	:		00h	
		0	1	:	:	:	:	:	:	:	:		00h	
		0	1	#	#	#	#	#	#	#	#		00h	
16	W2B LUT (LUTWB / LUTW) (42-byte command, bytes 2~7 repeated 7 times)	0	0	0	0	1	0	0	0	1	1		23h	
		0	1	#	#	#	#	#	#	#	#		00h	
		0	1	:	:	:	:	:	:	:	:		00h	
		0	1	:	:	:	:	:	:	:	:		00h	
		0	1	:	:	:	:	:	:	:	:		00h	
		0	1	#	#	#	#	#	#	#	#		00h	
17	B2B LUT (LUTBB / LUTB) (42-byte command, bytes 2~7 repeated 7 times)	0	0	0	0	1	0	0	1	0	0		24h	
		0	1	#	#	#	#	#	#	#	#		00h	
		0	1	:	:	:	:	:	:	:	:		00h	
		0	1	:	:	:	:	:	:	:	:		00h	
		0	1	:	:	:	:	:	:	:	:		00h	
		0	1	#	#	#	#	#	#	#	#		00h	
18	PLL control (PLL)	0	0	0	0	1	1	0	0	0	0	M[2:0], N[2:0]	30h	
		0	1	--	--	#	#	#	#	#	#		3Ch	
19	Temperature Sensor Calibration (TSC)	0	0	0	1	0	0	0	0	0	0	LM[10:3] / TSR[7:0]	40h	
		1	1	#	#	#	#	#	#	#	#			00h
		1	1	#	#	#	--	--	--	--	--	LM[2:0] / -	00h	
20	Temperature Sensor Selection (TSE)	0	0	0	1	0	0	0	0	0	1	TSE,TO[3:0]	41h	
		0	1	#	--	--	--	#	#	#	#			00h
21	Temperature Sensor Write (TSW)	0	0	0	1	0	0	0	0	1	0	WATTR[7:0] WMSB[7:0] WLSB[7:0]	42h	
		0	1	#	#	#	#	#	#	#	#			00h
		0	1	#	#	#	#	#	#	#	#			00h
22	Temperature Sensor Read (TSR)	0	0	0	1	0	0	0	0	1	1	RMSB[7:0] RLSB[7:0]	43h	
		1	1	#	#	#	#	#	#	#	#			00h
		1	1	#	#	#	#	#	#	#	#		00h	
23	Vcom and data interval setting (CDI)	0	0	0	1	0	1	0	0	0	0	VBD[1:0], DDX[1:0], CDI[3:0]	50h	
		0	1	#	#	#	#	#	#	#	#		D7h	
24	Lower Power Detection (LPD)	0	0	0	1	0	1	0	0	0	1	LPD	51h	
		1	1	--	--	--	--	--	--	--	#			01h
25	TCON setting (TCON)	0	0	0	1	1	0	0	0	0	0	S2G[3:0], G2S[3:0]	60h	
		0	1	#	#	#	#	#	#	#	#			22h

#	Command	W/R	C/D	D7	D6	D5	D4	D3	D2	D1	D0	Registers	Default
26	Resolution setting (TRES)	0	0	0	1	1	0	0	0	0	1	HRES[7:3] VRES[8:0]	61h
		0	1	#	#	#	#	#	0	0	0		00h
		0	1	--	--	--	--	--	--	--	#		00h
		0	1	#	#	#	#	#	#	#	#		00h
27	Revision (REV)	0	0	0	1	1	1	0	0	0	0	LUT_REV[7:0]	70h
		0	1	#	#	#	#	#	#	#	#		00h
28	Get Status (FLG)	0	0	0	1	1	1	0	0	0	1	PTL_FLAG, I ² C_ERR, I ² C_BUSYN, DATA_FLAG, PON, POF, BUSY_N	71h
		1	1	--	#	#	#	#	#	#	#		02h
29	Auto Measurement Vcom	0	0	1	0	0	0	0	0	0	0	AMVT[1:0], XON, AMVS, AMV, AMVE	80h
		0	1	--	--	#	#	#	#	#	#		10h
30	Read Vcom Value(VV)	0	0	1	0	0	0	0	0	0	1	VV[5:0]	81h
		1	1	--	--	#	#	#	#	#	#		00h
31	VCM_DC Setting (VDCS)	0	0	1	0	0	0	0	0	1	0	VDCS[5:0]	82h
		0	1	--	--	#	#	#	#	#	#		00h
32	Partial Window (PTL)	0	0	1	0	0	1	0	0	0	0	HRST[7:3] HRED[7:3] VRST[8:0] VRED[8:0] PT_SCAN	90h
		0	1	#	#	#	#	#	0	0	0		00h
		0	1	#	#	#	#	#	0	0	0		00h
		0	1	--	--	--	--	--	--	--	#		00h
		0	1	#	#	#	#	#	#	#	#		00h
		0	1	--	--	--	--	--	--	--	#		00h
		0	1	#	#	#	#	#	#	#	#		00h
33	Partial In (PTIN)	0	0	1	0	0	1	0	0	0	1		91h
34	Partial Out (PTOUT)	0	0	1	0	0	1	0	0	1	0		92h
35	Program Mode (PGM)	0	0	1	0	1	0	0	0	0	0	Check code = A5h	A0h
		0	1	1	0	1	0	0	1	0	1		A5h
36	Active Progrmming (APG)	0	0	1	0	1	0	0	0	0	1		A1h
37	Read OTP (ROTP)	0	0	1	0	1	0	0	0	1	0	Read Dummy Data of Address = 000h : Data of Address = n	A2h
		1	1	--	--	--	--	--	--	--	--		N/A
		1	1	#	#	#	#	#	#	#	#		N/A
		1	1	:	:	:	:	:	:	:	:		N/A
38	Cascade Setting (CCSET)	0	0	1	1	1	0	0	0	0	0	TSFIX, CCEN	E0h
		0	1	--	--	--	--	--	--	#	#		00h
39	Force Temperautre (TSSET)	0	0	1	1	1	0	0	1	0	1	TS_SET[7:0]	E5h
		0	1	#	#	#	#	#	#	#	#		00h

- Note:** (1) All other register addresses are invalid or reserved by UltraChip, and should NOT be used.
- (2) Any bits shown here as 0 must be written with a 0. All unused bits should also be set to zero. Device malfunction may occur if this is not done.
- (3) Commands are processed on the 'stop' condition of the interface.
- (4) Registers marked 'W/R' can be read, but the contents are written when the SPI command completes – so the contents can be read and altered. The user can subsequently write the register to restore the contents following an SPI read.

COMMAND DESCRIPTION

[W/R]: 0: Write Cycle / 1: Read Cycle **[C/D]**: 0: Command / 1: Data **[D7-D0]**: -: Don't Care

(1) PANEL SETTING (PSR) (REGISTER: R00H)

Action	W/R	C/D	D7	D6	D5	D4	D3	D2	D1	D0
Setting the panel	0	0	0	0	0	0	0	0	0	0
	0	1	RES1	RES0	REG_EN	BWR	UD	SHL	SHD_N	RST_N

RES[1:0]: Display Resolution setting (source x gate)
00b: 96x230 (Default) Active source channels: S0 ~ S95. Active gate channels: G0 ~ G229.
01b: 96x252 Active source channels: S0 ~ S95. Active gate channels: G0 ~ G251.
10b: 128x296 Active source channels: S0 ~ S127. Active gate channels: G0 ~ G295.
11b: 160x296 Active source channels: S0 ~ S159. Active gate channels: G0 ~ G295.

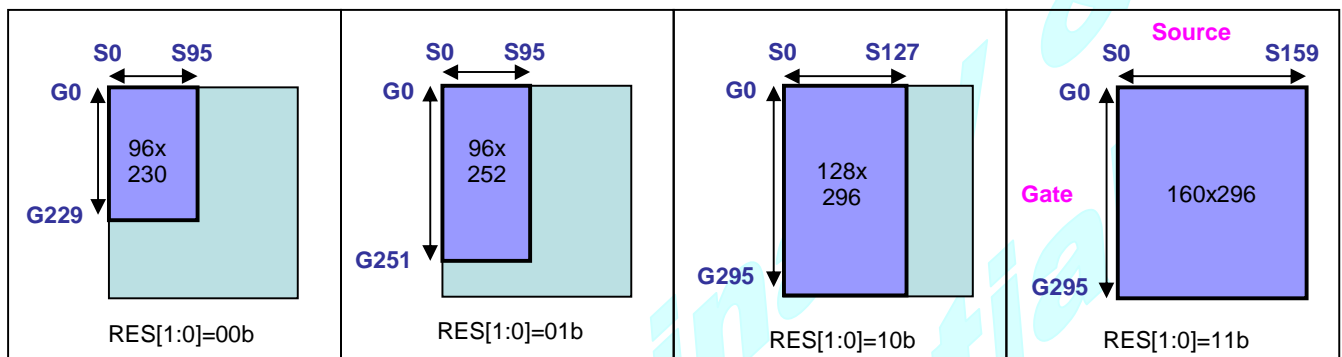

- (1) Minimum active GD is always G0 regardless of <UD>(R00H).
 - (2) Minimum active SD is always S0 regardless of <SHL>(R00H).
- Legend:
 maximum resolution
 active resolution

REG_EN: LUT selection
0: LUT from OTP. (Default)
 1: LUT from register.

BWR: Black / White / Red
0: Pixel with B/W/Red. Run both LU1 and LU2. (Default)
 1: Pixel with B/W. Run LU1 only.

UD: Gate Scan Direction
0: Scan down. First line to Last line: Gn-1 → Gn-2 → Gn-3 → ... → G0
1: Scan up. (Default) First line to Last line: G0 → G1 → G2 → ... → Gn-1

SHL: Source Shift Direction
0: Shift left. First data to Last data: Sn-1 → Sn-2 → Sn-3 → ... → S0
1: Shift right. (Default) First data to Last data: S0 → S1 → S2 → ... → Sn-1

SHD_N: Booster Switch
0: Booster OFF, register data are kept, and SEG/BG/VCOM are kept 0V or floating.
1: Booster ON (Default)
 When SHD_N become LOW, charge pump will be turned OFF, register and SRAM data will keep until VDD OFF, and SD output and VCOM will remain previous condition. SHD_N may have two conditions: 0v or floating.

RST_N: Soft Reset
1: No effect (Default). Booster OFF, Register data are set to their default values, and SEG/BG/VCOM: 0V
 When RST_N become LOW, the driver will be reset, all registers will be reset to their default value. All driver functions will be disabled. SD output and VCOM will base on previous condition. It may have two conditions: 0v or floating.

(2) POWER SETTING (PWR) (R01H)

Action	W/R	C/D	D7	D6	D5	D4	D3	D2	D1	D0	
Selecting Internal/External Power	0	0	0	0	0	0	0	0	0	1	01h
	0	1	-	-	-	-	-	-	VDS_EN	VDG_EN	03h
	0	1	-	-	-	-	-	VCOM_HV	VGHL_LV[1:0]		00h
	0	1	-	-	VDH[5:0]						26h
	0	1	-	-	VDL[5:0]						26h
	0	1	-	VDHR[6:0]							

VDS_EN: Source power selection
 0 : External source power from VD_H/VD_L pins
 1 : Internal DC/DC function for generating VD_H/VD_L

VDG_EN: Gate power selection
 0 : External gate power from VG_H/VG_L pins
 1 : Internal DC/DC function for generating VG_H/VG_L

VCOM_HV: VCOM Voltage Level
 0 : VCOM_H=VD_H+VCOM_DC, VCOM_L=VH_L+VCOM_DC
 1 : VCOM_L=VG_H, VCOM_L=VGL

VGHL_LV[1:0]: VG_H / VG_L Voltage Level selection.

VGHL_LV	VGHL Voltage Level
00 (DEFAULT)	VG _H =16V, VG _L = -16V
01	VG _H =15V, VG _L = -15V
10	VG _H =14V, VG _L = -14V
11	VG _H =13V, VG _L = -13V

VDH[5:0]: Internal VD_H power selection for B/W LUT. (Default value: 100110b)

VDH	VDH_V	VDH	VDH_V	VDH	VDH_V	VDH	VDH_V
000000	2.4 V	001100	4.8 V	011000	7.2 V	100100	9.6 V
000001	2.6 V	001101	5.0 V	011001	7.4 V	100101	9.8 V
000010	2.8 V	001110	5.2 V	011010	7.6 V	100110	10.0V
000011	3.0 V	001111	5.4 V	011011	7.8 V	100111	10.2 V
000100	3.2 V	010000	5.6 V	011100	8.0 V	101000	10.4 V
000101	3.4 V	010001	5.8 V	011101	8.2V	101001	10.6 V
000110	3.6 V	010010	6.0 V	011110	8.4 V	101010	10.8 V
000111	3.8 V	010011	6.2 V	011111	8.6 V	101011	11.0 V
001000	4.0 V	010100	6.4 V	100000	8.8 V	(others)	11.0 V
001001	4.2 V	010101	6.6 V	100001	9.0 V		
001010	4.4 V	010110	6.8 V	100010	9.2 V		
001011	4.6 V	010111	7.0 V	100011	9.4 V		

VDL[5:0]: Internal VD_L power selection for B/W LUT. (Default value: 100110b)

VDL	VDL_V	VDL	VDL_V	VDL	VDL_V	VDL	VDL_V
000000	-2.4 V	001100	-4.8 V	011000	-7.2 V	100100	-9.6 V
000001	-2.6 V	001101	-5.0 V	011001	-7.4 V	100101	-9.8 V
000010	-2.8 V	001110	-5.2 V	011010	-7.6 V	100110	-10.0V
000011	-3.0 V	001111	-5.4 V	011011	-7.8 V	100111	-10.2 V
000100	-3.2 V	010000	-5.6 V	011100	-8.0 V	101000	-10.4 V
000101	-3.4 V	010001	-5.8 V	011101	-8.2V	101001	-10.6 V
000110	-3.6 V	010010	-6.0 V	011110	-8.4 V	101010	-10.8 V
000111	-3.8 V	010011	-6.2 V	011111	-8.6 V	101011	-11.0 V
001000	-4.0 V	010100	-6.4 V	100000	-8.8 V	(others)	-11.0 V
001001	-4.2 V	010101	-6.6 V	100001	-9.0 V		
001010	-4.4 V	010110	-6.8 V	100010	-9.2 V		
001011	-4.6 V	010111	-7.0 V	100011	-9.4 V		

VDHR[5:0]: Internal VDL power selection for B/W LUT. (Default value: 000011b)

VDH	VDH_V	VDH	VDH_V	VDH	VDH_V	VDH	VDH_V
000000	2.4 V	001100	4.8 V	011000	7.2 V	100100	9.6 V
000001	2.6 V	001101	5.0 V	011001	7.4 V	100101	9.8 V
000010	2.8 V	001110	5.2 V	011010	7.6 V	100110	10.0V
000011	3.0 V	001111	5.4 V	011011	7.8 V	100111	10.2 V
000100	3.2 V	010000	5.6 V	011100	8.0 V	101000	10.4 V
000101	3.4 V	010001	5.8 V	011101	8.2V	101001	10.6 V
000110	3.6 V	010010	6.0 V	011110	8.4 V	101010	10.8 V
000111	3.8 V	010011	6.2 V	011111	8.6 V	101011	11.0 V
001000	4.0 V	010100	6.4 V	100000	8.8 V	(others)	11.0 V
001001	4.2 V	010101	6.6 V	100001	9.0 V		
001010	4.4 V	010110	6.8 V	100010	9.2 V		
001011	4.6 V	010111	7.0 V	100011	9.4 V		

(3) POWER OFF (POF) (R02H)

Action	W/R	C/D	D7	D6	D5	D4	D3	D2	D1	D0
Turning OFF the power	0	0	0	0	0	0	0	0	1	0

After the Power Off command, the driver will power off following the Power Off Sequence. This command will turn off charge pump, T-con, source driver, gate driver, VCOM, and temperature sensor, but register data will be kept until VDD becomes OFF.

SD output and Vcom will remain as previous condition, which may have 2 conditions: 0V or floating.

(4) POWER OFF SEQUENCE SETTING (PFS) (R03H)

Action	W/R	C/D	D7	D6	D5	D4	D3	D2	D1	D0
Setting Power OFF sequence	0	0	0	0	0	0	0	0	1	1
	0	1	-	-	T_VDS_OFF[1:0]	-	-	-	-	-

T_VDS_OFF[1:0]: Power OFF Sequence of VDH and VDL.

00b: 1 frame (Default) 01b: 2 frames 10b: 3 frames 11b: 4 frame

(5) POWER ON (PON) (REGISTER: R04H)

Action	W/R	C/D	D7	D6	D5	D4	D3	D2	D1	D0
Turning ON the power	0	0	0	0	0	0	0	1	0	0

After the Power ON command, the driver will be powered ON following the Power ON Sequence. Refer to the Power ON Sequence section.

(6) POWER ON MEASURE (PMES) (R05H)

Action	W/R	C/D	D7	D6	D5	D4	D3	D2	D1	D0
	0	0	0	0	0	0	0	1	0	1

This command enables the internal bandgap, which will be cleared by the next POF.

(7) BOOSTER SOFT START (BTST) (R06H)

Action	W/R	C/D	D7	D6	D5	D4	D3	D2	D1	D0
Starting data transmission	0	0	0	0	0	0	0	1	1	0
	0	1	BT_PHA7	BT_PHA6	BT_PHA5	BT_PHA4	BT_PHA3	BT_PHA2	BT_PHA1	BT_PHA0
	0	1	BT_PHB7	BT_PHB6	BT_PHB5	BT_PHB4	BT_PHB3	BT_PHB2	BT_PHB1	BT_PHB0
	0	1	-	-	BT_PHC5	BT_PHC4	BT_PHC3	BT_PHC2	BT_PHC1	BT_PHC0

BTPHA[6:5]: Soft start period of phase A.

00b: 10mS 01b: 20mS 10b: 30mS 11b: 40mS

BTPHA[4:3]: Driving strength of phase A

000b: strength 1 001b: strength 2 **010b: strength 3** 011b: strength 4
 000b: strength 5 001b: strength 6 010b: strength 7 011b: strength 8 (strongest)

BTPHA[2:0]: Minimum OFF time setting of GDR in phase B

000b: 0.27uS 001b: 0.34uS 010b: 0.40uS 011b: 0.54uS
 100b: 0.80uS 101b: 1.54uS 110b: 3.34uS **111b: 6.58uS**

BTPHB[6:5]: Soft start period of phase B.

00b: 10mS 01b: 20mS 10b: 30mS 11b: 40mS

BTPHB[4:3]: Driving strength of phase B

000b: strength 1 001b: strength 2 **010b: strength 3** 011b: strength 4
 000b: strength 5 001b: strength 6 010b: strength 7 011b: strength 8 (strongest)

BTPHB[2:0]: Minimum OFF time setting of GDR in phase B

000b: 0.27uS 001b: 0.34uS 010b: 0.40uS 011b: 0.54uS
 100b: 0.80uS 101b: 1.54uS 110b: 3.34uS **111b: 6.58uS**

BTPHC[4:3]: Driving strength of phase C

000b: strength 1 001b: strength 2 **010b: strength 3** 011b: strength 4
 000b: strength 5 001b: strength 6 010b: strength 7 011b: strength 8 (strongest)

BTPHC[2:0]: Minimum OFF time setting of GDR in phase C

000b: 0.27uS 001b: 0.34uS 010b: 0.40uS 011b: 0.54uS
 100b: 0.80uS 101b: 1.54uS 110b: 3.34uS **111b: 6.58uS**

(8) DEEP SLEEP (DSLPL) (R07H)

Action	W/R	C/D	D7	D6	D5	D4	D3	D2	D1	D0
Deep Sleep	0	0	0	0	0	0	0	1	1	1
	0	1	1	0	1	0	0	1	0	1

After this command is transmitted, the chip would enter the deep-sleep mode to save power.

The deep sleep mode would return to standby by hardware reset.

The only one parameter is a check code, the command would be executed if check code = 0xA5.

(9) DATA START TRANSMISSION 1 (DTM1) (R10H)

Action	W/R	C/D	D7	D6	D5	D4	D3	D2	D1	D0
Starting data transmission	0	0	0	0	0	1	0	0	0	0
	0	1	Pixel1	Pixel2	Pixel3	Pixel4	Pixel5	Pixel6	Pixel7	Pixel8
	0	1	:	:	:	:	:	:	:	:
	0	1	Pixel(n-7)	Pixel(n-6)	Pixel(n-5)	Pixel(n-4)	Pixel(n-3)	Pixel(n-2)	Pixel(n-1)	Pixel(n)

This command starts transmitting data and write them into SRAM. To complete data transmission, command DSP (Data transmission Stop) must be issued. Then the chip will start to send data/VCOM for panel.

In B/W mode, this command writes "OLD" data to SRAM.

In B/W/Red mode, this command writes "B/W" data to SRAM.

In Program mode, this command writes "OTP" data to SRAM for programming.

(10) DATA STOP (DSP) (R11H)

Action	W/R	C/D	D7	D6	D5	D4	D3	D2	D1	D0
Stopping data transmission	0	0	0	0	0	1	0	0	0	1
	1	1	data_flag	-	-	-	-	-	-	-

To stop data transmission, this command must be issued to check the data_flag.

Data_flag: Data flag of receiving user data.

0: Driver didn't receive all the data.

1: Driver has already received all the one-frame data (DTM1 and DTM2).

After "Data Start" (10h) or "Data Stop" (11h) commands and when data_flag=1, BUSY_N signal will become "0" and the refreshing of panel starts.

(11) DISPLAY REFRESH (DRF) (R12H)

Action	W/R	C/D	D7	D6	D5	D4	D3	D2	D1	D0
Refreshing the display	0	0	0	0	0	1	0	0	1	0

While user sent this command, driver will refresh display (data/VCOM) according to SRAM data and LUT.

After Display Refresh command, BUSY_N signal will become "0" and the refreshing of panel starts.

(12) DATA START TRANSMISSION 2 (DTM2) (R13H)

Action	W/R	C/D	D7	D6	D5	D4	D3	D2	D1	D0
Starting data transmission	0	0	0	0	0	1	0	0	0	0
	0	1	Pixel1	Pixel2	Pixel3	Pixel4	Pixel5	Pixel6	Pixel7	Pixel8
	0	1	:	:	:	:	:	:	:	:
	0	1	Pixel(n-7)	Pixel(n-6)	Pixel(n-5)	Pixel(n-4)	Pixel(n-3)	Pixel(n-2)	Pixel(n-1)	Pixel(n)

This command starts transmitting data and write them into SRAM. To complete data transmission, command DSP (Data transmission Stop) must be issued. Then the chip will start to send data/VCOM for panel.

In B/W mode, this command writes "NEW" data to SRAM.

In B/W/Red mode, this command writes "RED" data to SRAM.

(13) VCOM LUT (LUTC) (R20H)

Action	W/R	C/D	D7	D6	D5	D4	D3	D2	D1	D0		
Build Look-up Table for VCOM (45-byte command, bytes 2~7 repeated 7 times)	0	0	0	0	1	0	0	0	0	0	20h	
	0	1	LEVEL SELECT-0		LEVEL SELECT-1		LEVEL SELECT-2		LEVEL SELECT-3		00h	
	0	1	NUMBER OF FRAMES-0									00h
	0	1	NUMBER OF FRAMES-1									00h
	0	1	NUMBER OF FRAMES-2									00h
	0	1	NUMBER OF FRAMES-3									00h
	0	1	TIMES TO REPEAT									00h
	0	1	-							ST_XON[6:0]		00h
	0	1	-							ST_CHV[6:0]		00h

This command stores VCOM Look-Up Table with 7 groups of data. Each group contains information for one state and is stored with 6 bytes, while the sixth byte indicates how many times that phase will repeat.

Bytes 2, 8, 14, 20, 26, 32, 38:

Level Selection.

- 00b: VCM_DC
- 01b: VDH+VCM_DC (VCOMH)
- 10b: VDL+VCM_DC (VCOML)
- 11b: Floating

Bytes 3~6, 9~12, 15~18, 21~24, 27~30, 33~36, 39~42:

Number of Frames

- 0000 0000b: 0 frame
- : :
- : :
- 1111 1111b: 256 frames

Bytes 7, 13, 19, 25, 31, 37, 43:

Times to Repeat

- 0000 0000b: 0 time
- : :
- : :
- 1111 1111b: 256 times

Bytes 44:

All Gate ON (ST_XON [6:0] one hot for each state, ST_XON [0] for state-1, ST_XON [1] for state-2)

- 0000 0000b: no All Gate ON
- 0000 0001b: State-1 All Gate ON
- 0000 0011b: State-1 and State2 All Gate ON
- : :

Bytes 45:

VCOM High Voltage (ST_CHV [6:0] one hot for each state, ST_CHV [0] for state-1, ST_CHV [1] for state-2)

- 0000 0000b: no VCOM High Voltage
- 0000 0001b: State-1 VCOM High Voltage
- 0000 0011b: State-1 and State2 VCOM High Voltage
- : :

(14) W2W LUT (LUTWW) (R21H)

Action	W/R	C/D	D7	D6	D5	D4	D3	D2	D1	D0
Build White Look-up Table for W2W (43-byte command, bytes 2~7 repeated 7 times)	0	0	0	0	1	0	0	0	0	1
	0	1	LEVEL SELECT-0	LEVEL SELECT-1	LEVEL SELECT-2	LEVEL SELECT-3				
	0	1	NUMBER OF FRAMES-0							
	0	1	NUMBER OF FRAMES-1							
	0	1	NUMBER OF FRAMES-2							
	0	1	NUMBER OF FRAMES-3							
	0	1	TIMES TO REPEAT							

This command stores White-to-White Look-Up Table with 7 groups of data. Each group contains information for one state and is stored with 6 bytes, while the sixth byte indicates how many times that phase will repeat.

Bytes 2, 8, 14, 20, 26, 32, 38:

Level Selection.

- 00b: GND
- 01b: VDH
- 10b: VDL
- 11b: VDHR

Bytes 3~6, 9~12, 15~18, 21~24, 27~30, 33~36, 39~42:

Number of Frames

- 0000 0000b: 0 frame
- : :
- : :
- 1111 1111b: 256 frames

Bytes 7, 13, 19, 25, 31, 37, 43:

Times to Repeat

- 0000 0000b: 0 time
- : :
- : :
- 1111 1111b: 256 times

(15) B2W LUT (LUTBW / LUTR) (R22H)

This command builds Look-up Table for Black-to-White. Please refer to W2W LUT (LUTWW) for similar definition details.

(16) W2B LUT (LUTWB / LUTW) (R23H)

This command builds Look-up Table for White-to-Black. Please refer to W2W LUT (LUTWW) for similar definition details.

(17) B2B LUT (LUTBB / LUTB) (R24H)

This command builds Look-up Table for Black-to-Black. Please refer to W2W LUT (LUTWW) for similar definition details.

(18) PLL CONTROL (PLL) (R30H)

Action	W/R	C/D	D7	D6	D5	D4	D3	D2	D1	D0
Controlling PLL	0	0	0	0	1	1	0	0	0	0
	0	1	-	-	M[2:0]			N[2:0]		

The command controls the PLL clock frequency. The PLL structure must support the following frame rates:

M	N	Frame rate
1	1	29 Hz
	2	14 Hz
	3	10 Hz
	4	7 Hz
	5	6 Hz
	6	5 Hz
	7	4 Hz
2	1	57 Hz
	2	29 Hz
	3	19 Hz
	4	14 Hz
	5	11 Hz
	6	10 Hz
	7	8 Hz

M	N	Frame rate
3	1	86 Hz
	2	43 Hz
	3	29 Hz
	4	21 Hz
	5	17 Hz
	6	14 Hz
	7	12 Hz
4	1	114 Hz
	2	57 Hz
	3	38 Hz
	4	29 Hz
	5	23 Hz
	6	19 Hz
	7	16 Hz

M	N	Frame rate
5	1	150 Hz
	2	72 Hz
	3	48 Hz
	4	36 Hz
	5	29 Hz
	6	24 Hz
	7	20 Hz
6	1	171 Hz
	2	86 Hz
	3	57 Hz
	4	43 Hz
	5	34 Hz
	6	29 Hz
	7	24 Hz

M	N	Frame rate
7	1	200 Hz
	2	100 Hz
	3	67 Hz
	4	50 Hz (default)
	5	40 Hz
	6	33 Hz
	7	29 Hz

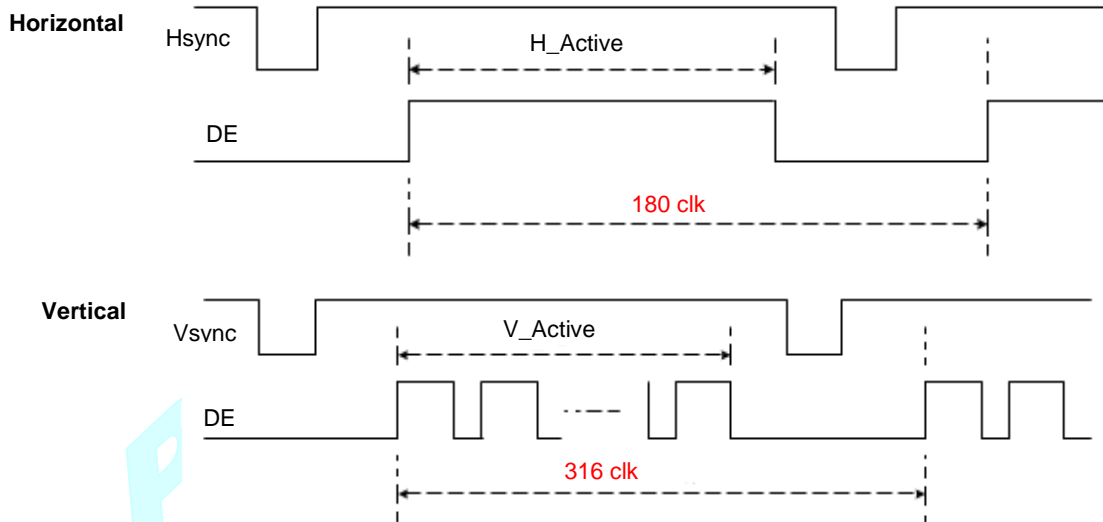

(19) TEMPERATURE SENSOR CALIBRATION (TSC) (R40H)

Action	W/R	C/D	D7	D6	D5	D4	D3	D2	D1	D0
Sensing Temperature	0	0	0	1	0	0	0	0	0	0
	1	1	D10/TS7	D9/TS6	D8/TS5	D7/TS4	D6 / TS3	D5 / TS2	D4 / TS1	D3 / TS0
	1	1	D2	D1	D0	-	-	-	-	-

This command reads the temperature sensed by the temperature sensor.

TS[7:0]: When TSE (R41h) is set to 0, this command reads internal temperature sensor value.

D[10:0]: When TSE (R41h) is set to 1, this command reads external LM75 temperature sensor value.

(20) TEMPERATURE SENSOR ENABLE (TSE) (R41H)

Action	W/R	C/D	D7	D6	D5	D4	D3	D2	D1	D0	
Calibrate Temperature Sensor	0	0	0	1	0	0	0	0	0	1	41h
	0	1	TSE	-	-	-	TO[3:0]				00h

This command selects Internal or External temperature sensor.

TSE: Internal temperature sensor switch

0: Enable (default)

1: Disable; using external sensor.

TO[3:0]: Temperature offset.

(21) TEMPERATURE SENSOR WRITE (TSW) (R42H)

Action	W/R	C/D	D7	D6	D5	D4	D3	D2	D1	D0	
Calibrate Temperature Sensor	0	0	0	1	0	0	0	0	1	0	42h
	0	1	WATTR[7:0]								00h
	0	1	WMSB[7:0]								00h
	0	1	WLSB[7:0]								00h

This command reads the temperature sensed by the temperature sensor.

WATTR: D[7:6]: I²C Write Byte Number
 00 : 1 byte (head byte only)
 01 : 2 bytes (head byte + pointer)
 10 : 3 bytes (head byte + pointer + 1st parameter)
 11 : 4 bytes (head byte + pointer + 1st parameter + 2nd parameter)

D[5:3]: User-defined address bits (A2, A1, A0)

D[2:0]: Pointer setting

WMSB[7:0]: MSByte of write-data to external temperature sensor

WLSB[7:0]: LSByte of write-data to external temperature sensor

(22) TEMPERATURE SENSOR READ (TSR) (R43H)

Action	W/R	C/D	D7	D6	D5	D4	D3	D2	D1	D0	
Calibrate Temperature Sensor	0	0	0	1	0	0	0	0	1	1	43h
	1	1	RMSB[7:0]								00h
	1	1	RLSB[7:0]								00h

This command reads the temperature sensed by the temperature sensor.

RMSB[7:0]: MSByte read data from external temperature sensor

RLSB[7:0]: LSByte read data from external temperature sensor

(23) VCOM AND DATA INTERVAL SETTING (CDI) (R50H)

Action	W/R	C/D	D7	D6	D5	D4	D3	D2	D1	D0
Set Interval between Vcom and Data	0	0	0	1	0	1	0	0	0	0
	0	1	VBD[1:0]		DDX[1:0]		CDI[3:0]			

This command indicates the interval of Vcom and data output. When setting the vertical back porch, the total blanking will be kept (20 Hsync).

VBD[1:0]: Border data selection

DDX[1:0]: Data polarity.

DDX[1] for RED data, DDX[0] for BW data in the B/W/Red mode.

DDX[0] for B/W mode.

CDI[3:0]: Vcom and data interval

CDI[3:0]	Vcom and Data Interval	CDI[3:0]	Vcom and Data Interval
0000 b	17 hsync	1000	9
0001	16	1001	8
0010	15	1010	7
0011	14	1011	6
0100	13	1100	5
0101	12	1101	4
0110	11	1110	3
0111	10 (Default)	1111	2

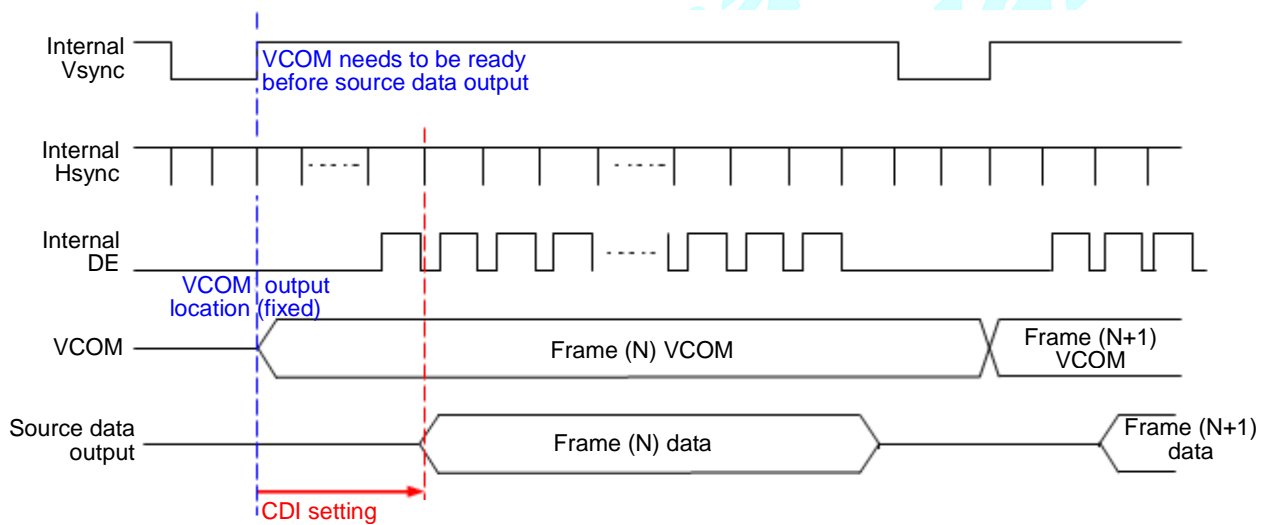

(24) LOW POWER DETECTION (LPD) (R51H)

Action	W/R	C/D	D7	D6	D5	D4	D3	D2	D1	D0
Detect Low Power	0	0	0	1	0	1	0	0	0	1
	1	1	-	-	-	-	-	-	-	LPD

This command indicates the input power condition. Host can read this flag to learn the battery condition.

LPD: Internal temperature sensor switch

0: Low power input (V_{DD}<2.5V)

1: Normal status (default)

(25) TCON SETTING (TCON) (R60H)

Action	W/R	C/D	D7	D6	D5	D4	D3	D2	D1	D0
Sensing Temperature	0	0	0	1	1	0	0	0	0	0
	0	1	S2G[3:0]				G2S[3:0]			

This command defines non-overlap period of Gate and Source.

S2G[3:0] or G2S[3:0]: Source to Gate / Gate to Source Non-overlap period

S2G[3:0] or G2S[3:0]	Period	S2G[3:0] or G2S[3:0]	Period
0000 b	4	1000 b	36
0001	8	1001	40
0010	12 (Default)	1010	44
0011	16	1011	48
0100	20	1100	52
0101	24	1101	56
0110	28	1110	60
0111	32	1111	64

Period = 660 nS.

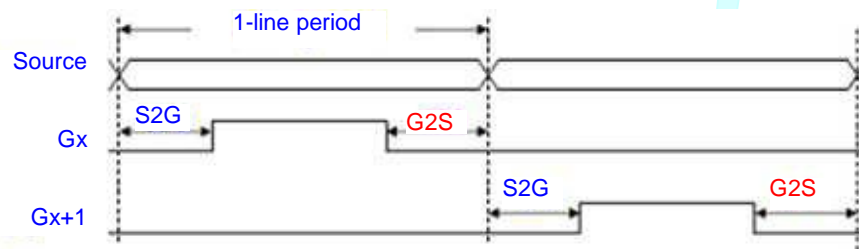

(26) RESOLUTION SETTING (TRES) (R61H)

Action	W/R	C/D	D7	D6	D5	D4	D3	D2	D1	D0	
Set Display Resolution	0	0	0	1	1	0	0	0	0	1	
	0	1	HRES[7:3]						0	0	0
	0	1	-	-	-	-	-	-	-	-	VRES[8]
VRES[7:0]											

This command defines alternative resolution and this setting is of higher priority than the RES[1:0] in R00H (PSR).

HRES[7:3]: Horizontal Display Resolution

VRES[8:0]: Vertical Display Resolution

Active channel calculation:

GD : First G active = G0; LAST active GD= first active +VRES[8:0] -1

SD : First active channel = S0 ; LAST active SD= first active +HRES[7:3]*8-1

EX :128x296

GD: First G active = G0, LAST active GD= 0+296-1= 295; (G295)

SD: First active channel = S0, LAST active SD= 0+128-1=93; (S127)

(27) REVISION (REV) (R70H)

Action	W/R	C/D	D7	D6	D5	D4	D3	D2	D1	D0
Chip Revision	0	0	0	1	1	1	0	0	0	0
	1	1	LUT_REV							

The LUT_REV is read from OTP address = 0x001.

(28) GET STATUS (FLG) (R71H)

Action	W/R	C/D	D7	D6	D5	D4	D3	D2	D1	D0
Read Flags	0	0	0	1	1	1	0	0	0	1
	1	1	-	PTL_flag	I ² C_ERR	I ² C_BUSYN	data_flag	PON	POF	BUSY_N

This command reads the IC status.

PTL_FLAG Partial display status (high: partial mode)

I²C_ERR: I²C master error status

I²C_BUSYN: I²C master busy status (low active)

data_flag: Driver has already received all the one frame data

PON: Power ON status

POF: Power OFF status

BUSY_N: Driver busy status (low active)

(29) AUTO MEASURE VCOM (AMV) (R80H)

Action	W/R	C/D	D7	D6	D5	D4	D3	D2	D1	D0
Automatically measure Vcom	0	0	1	0	0	0	0	0	0	0
	0	1	-	-	AMVT[1:0]	XON	AMVS	AMV	AMVE	

This command reads the IC status.

AMVT[1:0]: Auto Measure Vcom Time

00b: 3s

01b: 5s (default)

10b: 8s

11b: 10s

XON: All Gate ON of AMV

0: Gate normally scan during Auto Measure VCOM period. (default)

1: All Gate ON during Auto Measure VCOM period.

AMVS: Source output of AMV

0: Source output 0V during Auto Measure VCOM period. (default)

1: Source output VDHR during Auto Measure VCOM period.

AMV: Analog signal

0: Get Vcom value with the VV command (R81h) (default)

1: Get Vcom value in analog signal.

AMVE: Auto Measure Vcom Enable (/Disable)

0: No effect

1: Trigger auto Vcom sensing.

(30) VCOM VALUE (VV) (R81H)

Action	W/R	C/D	D7	D6	D5	D4	D3	D2	D1	D0
Automatically measure Vcom	0	0	1	0	0	0	0	0	0	1
	1	1	-	-	VV[5:0]					

81h
00h

This command gets the Vcom value.

VV[5:0]: Vcom Value Output

VV[5:0]	Vcom value
00 0000b	-0.10 V
00 0001b	-0.15 V
00 0010b	-0.20 V
:	:
11 1010b	-3.00 V

(31) VCM_DC SETTING (VDCS) (R82H)

Action	W/R	C/D	D7	D6	D5	D4	D3	D2	D1	D0
Set VCM_DC	0	0	1	0	0	0	0	0	1	0
	0	1	-	-	VDCS[5:0]					

82h
00h

This command sets VCOM_DC value

VDCS[5:0]: VCOM_DC Setting

VDCS[5:0]	Vcom value
00 0000b	-0.10 V (default)
00 0001b	-0.15 V
00 0010b	-0.20 V
:	:
11 1010b	-3.00 V

(32) PARTIAL WINDOW (PTL) (R90H)

Action	W/R	C/D	D7	D6	D5	D4	D3	D2	D1	D0	
Set Partial Window	0	0	1	0	0	0	0	0	1	0	
	0	1	HRST[7:3]					0	0	0	
	0	1	HRED[7:3]					0	0	0	
	0	1	-	-	-	-	-	-	-	VRST[8]	
	0	1	VRST[7:0]								
	0	1	-	-	-	-	-	-	-	VRED[8]	
	0	1	VRED[7:0]								
	0	1	-	-	-	-	-	-	-	PT_SCAN	

This command sets partial window.

HRST[7:3]: Horizontal start bank. (value 00h~13h)

HRED[7:3]: Horizontal end bank. (value 00h~13h). HRED must be greater than HRST.

VRST[8:0]: Horizontal start bank. (value 000h~127h)

VRED[8:0]: Horizontal end bank. (value 000h~127h). VRED must be greater than VRST.

PT_SCAN: 0: Gates scan only inside of the window.

1: Gates scan only outside of the window. (default)

(33) PARTIAL IN (PTIN) (R91H)

Action	W/R	C/D	D7	D6	D5	D4	D3	D2	D1	D0
Partial In	0	0	1	0	0	1	0	0	0	1

This command makes the display enter partial mode.

(34) PARTIAL OUT (PTOUT) (R92H)

Action	W/R	C/D	D7	D6	D5	D4	D3	D2	D1	D0
Partial Out	0	0	1	0	0	1	0	0	1	0

This command makes the display exit partial mode and enter normal mode.

(35) PROGRAM MODE (PGM) (RA0H)

Action	W/R	C/D	D7	D6	D5	D4	D3	D2	D1	D0
Enter Program Mode	0	0	1	0	1	0	0	0	0	0
	0	1	1	0	1	0	0	1	0	1

After this command is issued, the chip would enter the program mode.

The mode would return to standby by hardware reset.

The only one parameter is a check code, the command would be executed if check code = 0xA5.

(36) ACTIVE PROGRAM (APG) (RA1H)

Action	W/R	C/D	D7	D6	D5	D4	D3	D2	D1	D0
Active Program OTP	0	0	1	0	1	0	0	0	0	1

After this command is transmitted, the programming state machine would be activated.

The BUSY flag would fall to 0 until the programming is completed.

(37) READ OTP DATA (ROTP) (RA2H)

Action	W/R	C/D	D7	D6	D5	D4	D3	D2	D1	D0
Read OTP data for check	0	0	1	0	1	0	0	0	1	0
	1	1	Dummy							
	1	1	The data of address 0x000 in the OTP							
	1	1	The data of address 0x001 in the OTP							
	1	1	:							
	1	1	The data of address (n-1) in the OTP							
	1	1	The data of address (n) in the OTP							

The command is used for reading the content of OTP for checking the data of programming.

The value of (n) is depending on the amount of programmed data, the max address = 0xFFF.

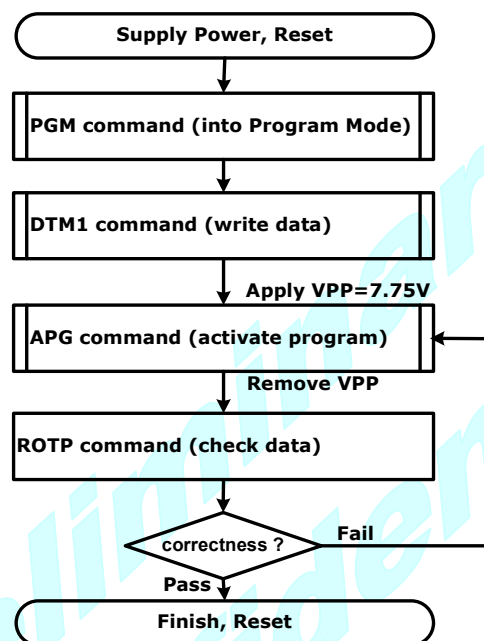

The sequence of programming OTP.

(38) CASCADE SETTING (CCSET) (RE0H)

Action	W/R	C/D	D7	D6	D5	D4	D3	D2	D1	D0
Set Cascade Option	0	0	1	1	1	0	0	0	0	0
	0	1	-	-	-	-	-	-	TSFIX	CCEN

This command is used for cascade.

CCEN: Output clock enable/disable.

0: Output 0V at CL pin. (default)

1: Output clock at CL pin for slave chip.

TSFIX: Let the value of slave's temperature is same as the masters'.

0: Temperature value is defined by internal temperature sensor / external LM75. (default)

1: Temperature value is defined by TS_SET[7:0] registers.

(39) FORCE TEMPERATURE (TSSET) (RE5H)

Action	W/R	C/D	D7	D6	D5	D4	D3	D2	D1	D0
Force Temperature Value for Cascade	0	0	1	1	1	0	0	1	0	1
	0	1	TS_SET[7:0]							

E5h
00h

This command is used for cascade to fix the temperature value of master and slave chip.

Preliminary & Confidential

HOST INTERFACES

3-WIRE SPI

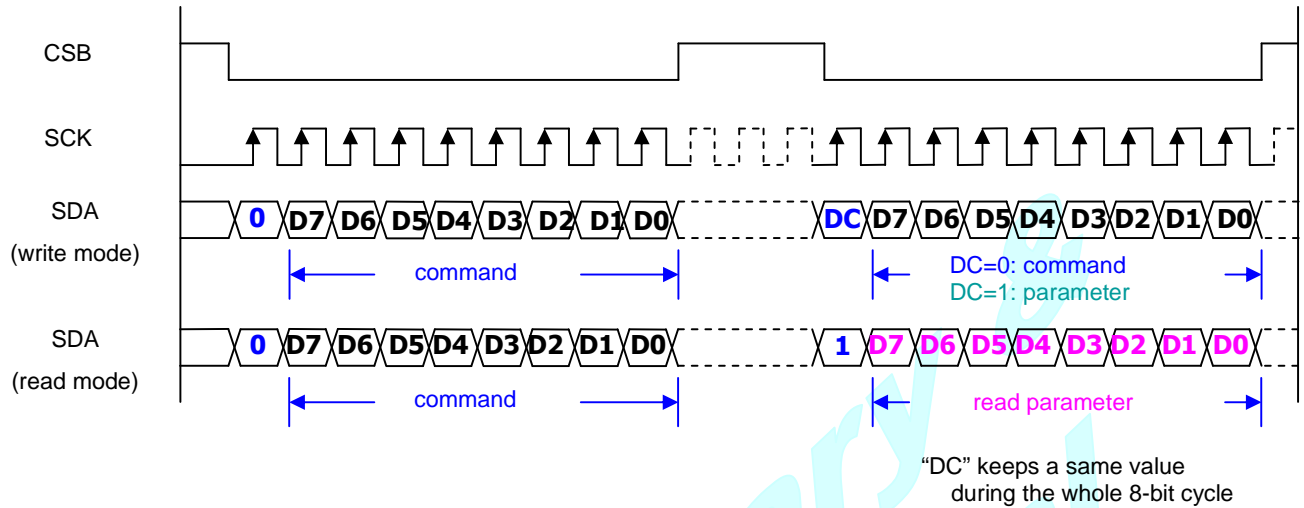

Figure : 3-wire SPI Typical Waveform – BS=1

4-WIRE SPI

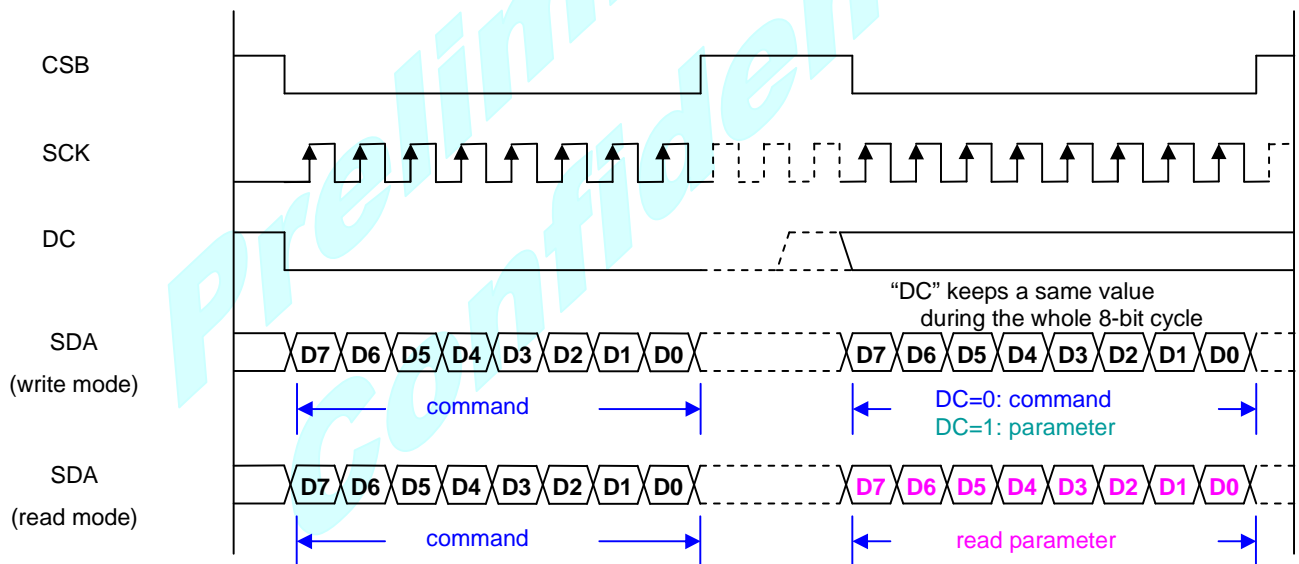
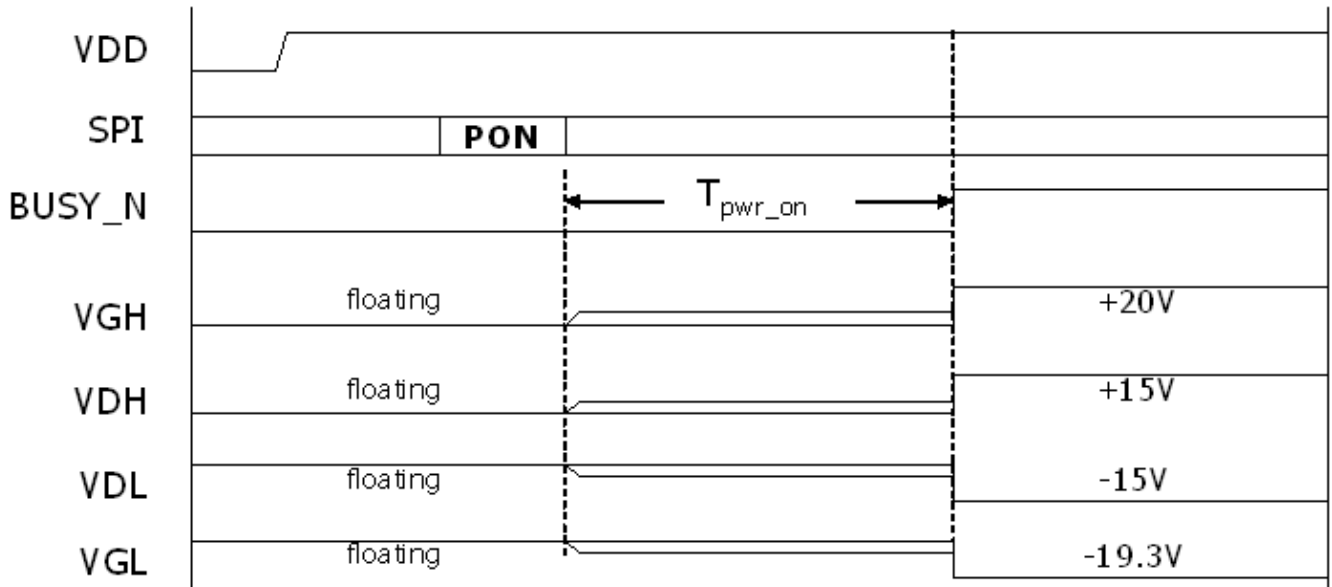

Figure : 4-wire Serial Interface – BS=0

POWER MANAGEMENT

Power ON Sequence



$T_{pwr_on} = \sim 80ms$ (default)

Preliminary
Confidential

Power OFF Sequence

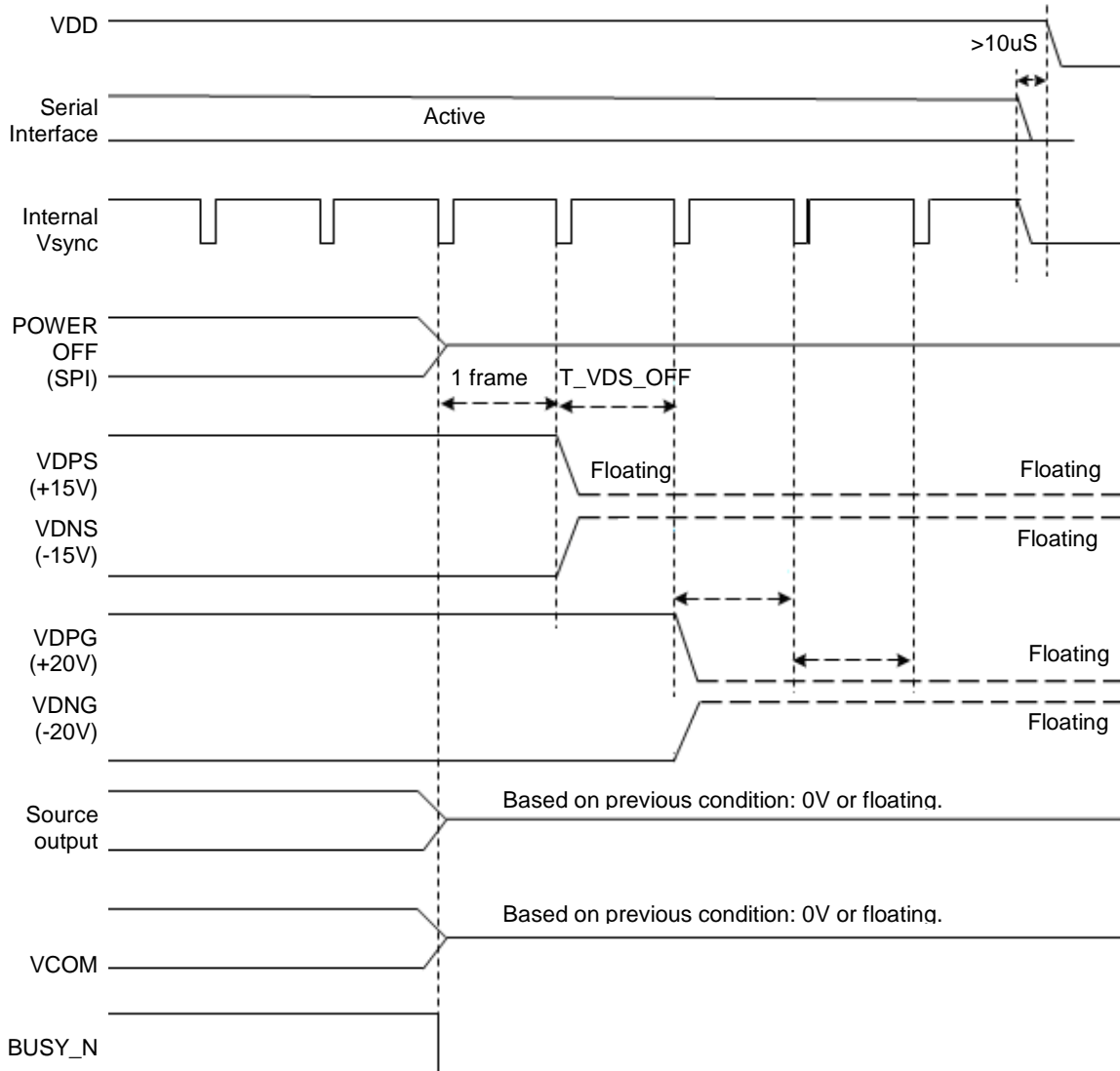

COV

Data Transmission Waveform

Example 1: LUT all states (7 states) complete or phase number=0, the driver will send 2 frame VCOM and data to 0 V.

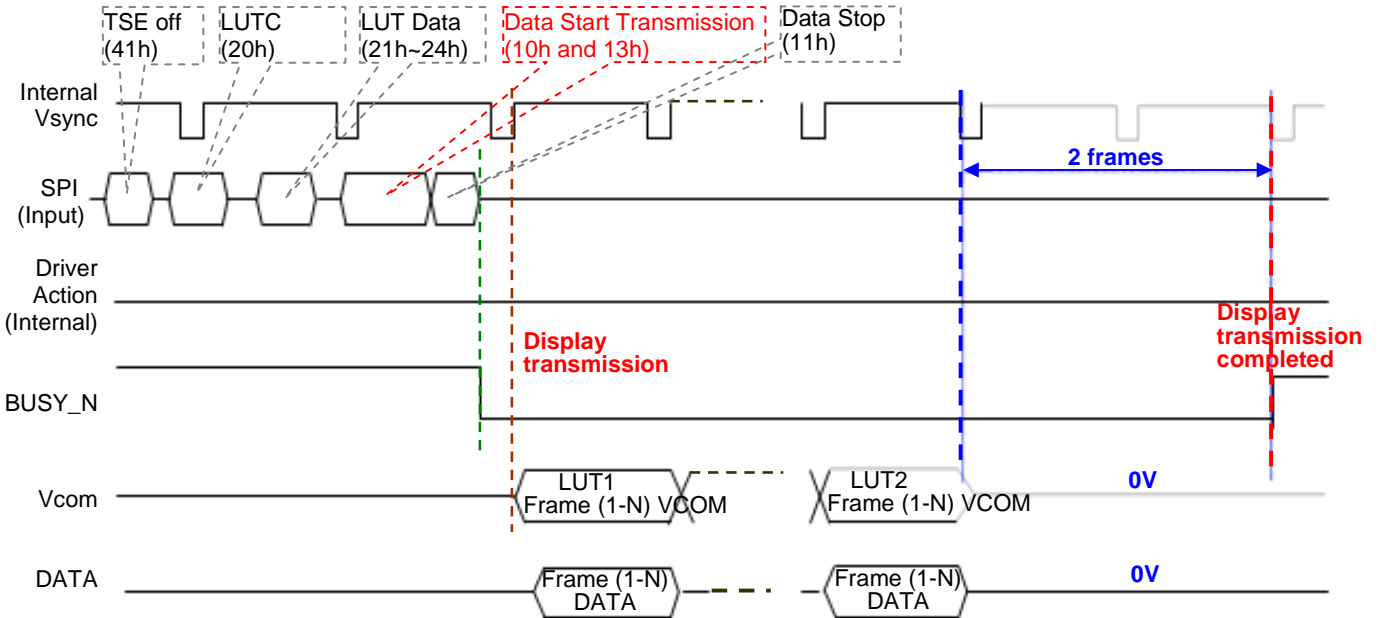

Example 2: While level selection in LUT is "11", the driver will float VCOM and data.

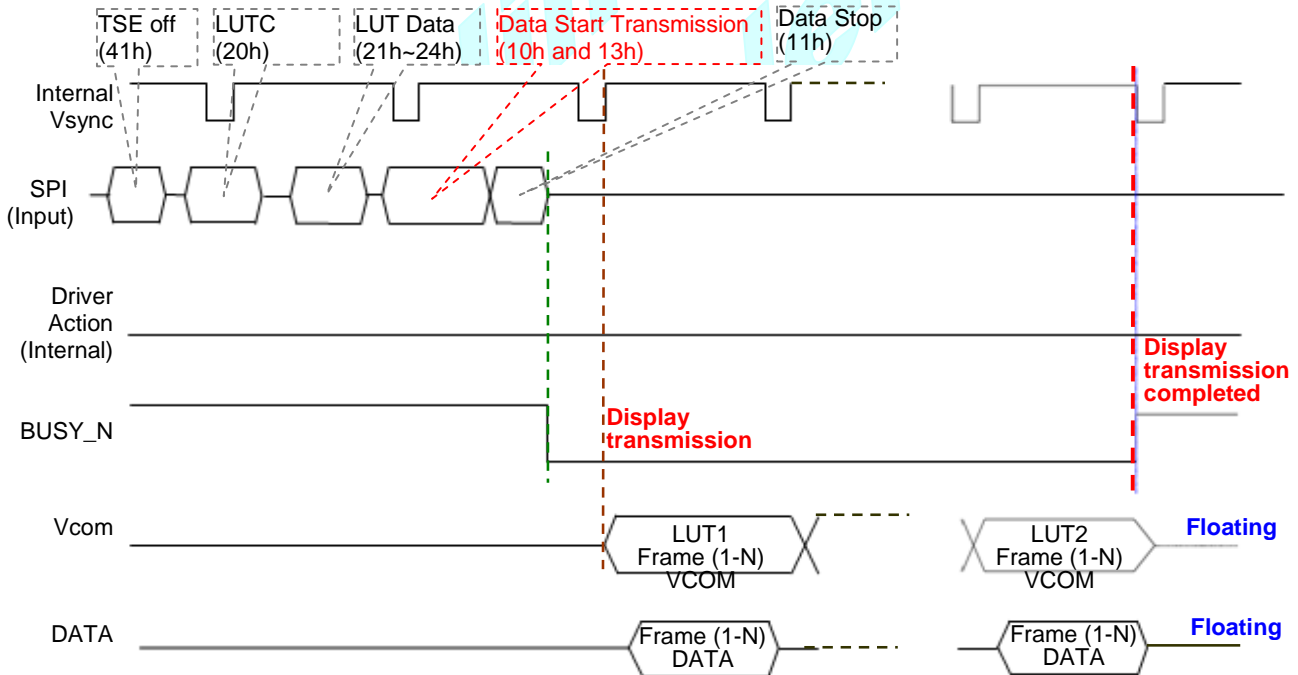

Display Refresh Waveform

Example 1: LUT all states (7 states) complete or phase number=0, the driver will send 2 frame VCOM and data to 0 V.

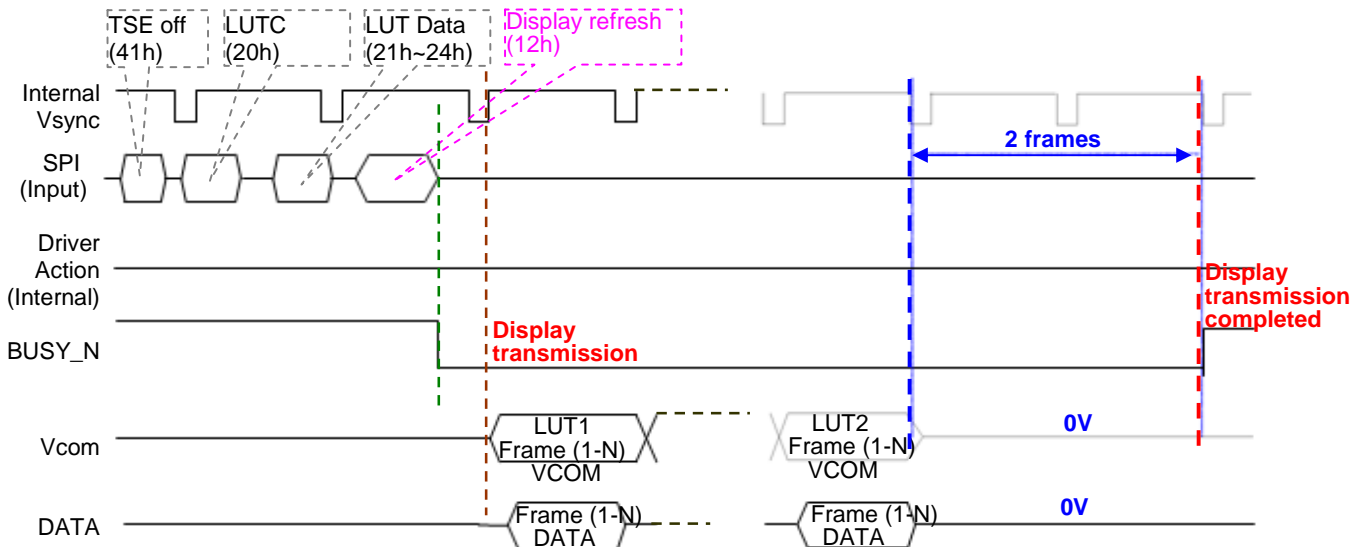

Example 2: While level selection in LUT is "11", the driver will float VCOM and data.

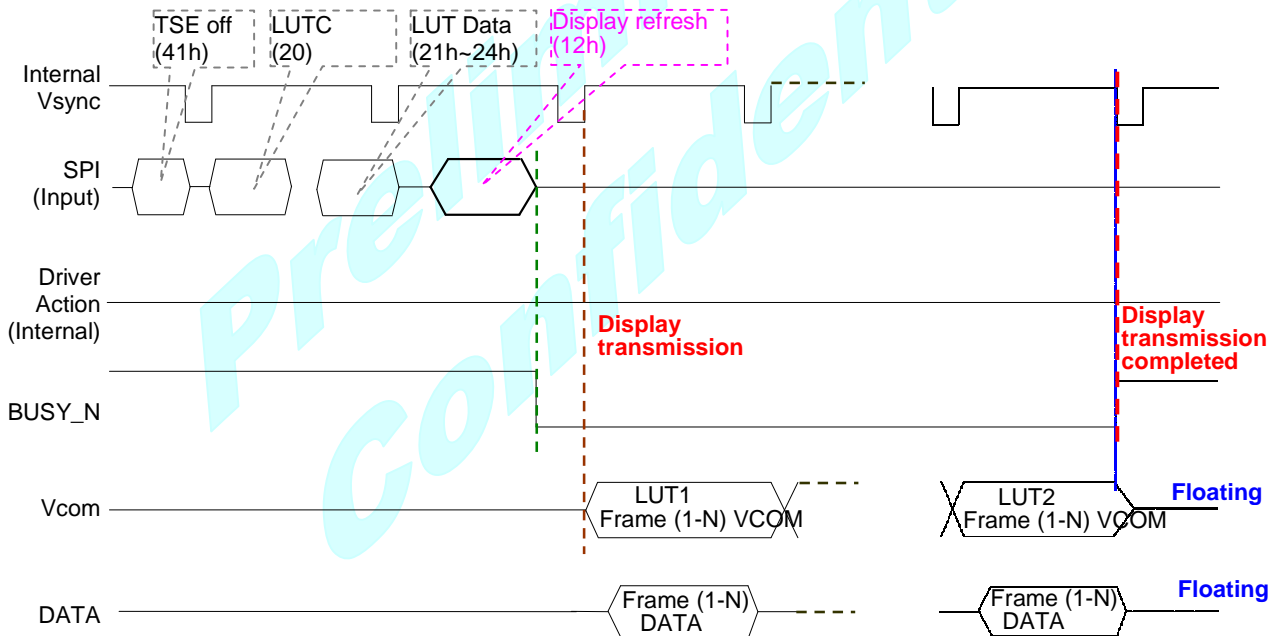

BUSY N Signal Flow Chart

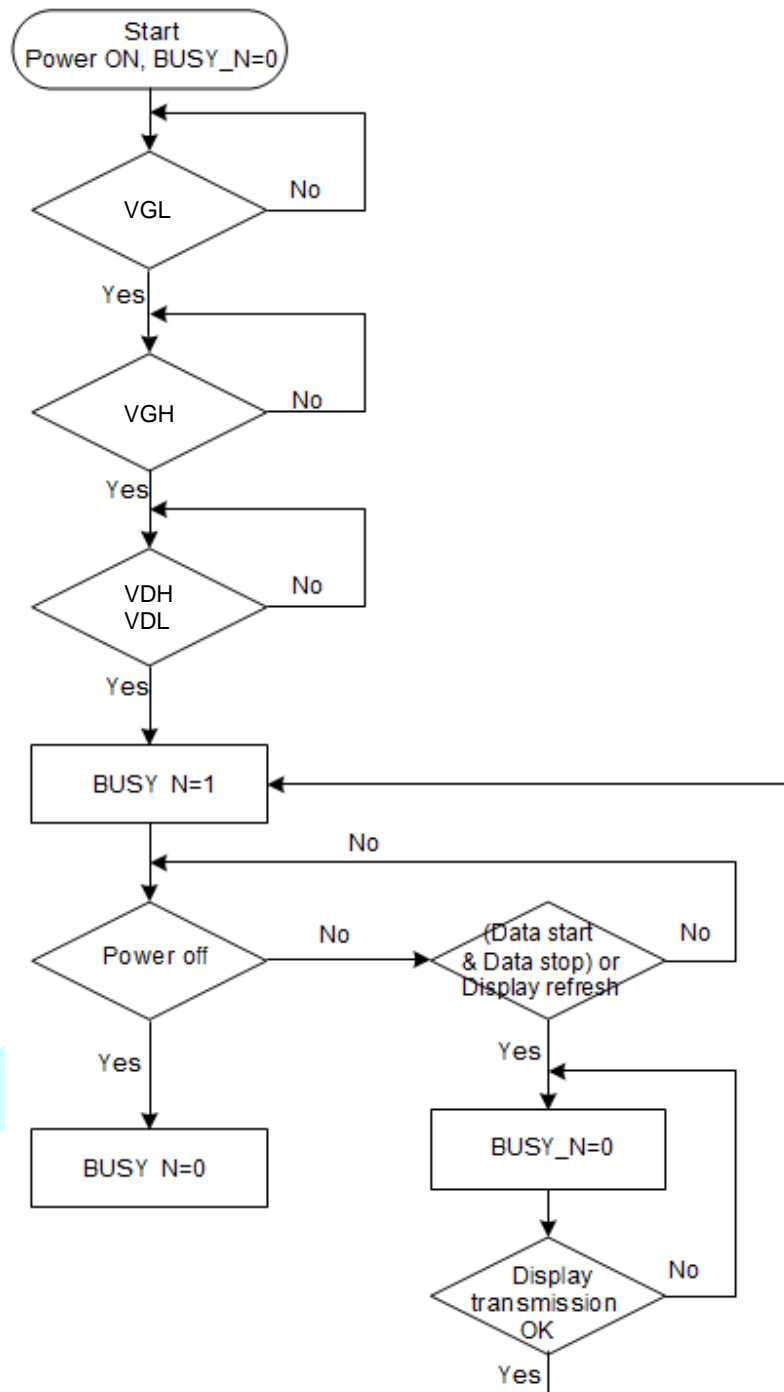

BUSY_N Signal Flow Chart

ABSOLUTE MAXIMUM RATINGS

V_{DD}/AV_{DD} = 2~3.6V (Typ. 3.3V), GND=0V, V_{DH}=2.4~11V (Typ. 10V), V_{DL}=-2.4~-11V (Typ. -10V), T_A=0~70°C (Typ. 25°C)

Signal	Item	Min	Max.	Unit
V _{DD} , V _{IO} , AV _{DD} , V _{PP}	Logic Supply voltage	-0.3	+6.0	V
V _I	Digital input range	-0.3	V _{DDIO} +40	V
V _{GH} -V _{GL}	Supply range	V _{GL} -0.3	V _{GH} +0.3	V
Source				
V _{DH}	Analog supply voltage – positive		+20	V
V _{DL}	Analog supply voltage -- negative		-20	V
V _{DHR}	Analog supply voltage – positive		+20	V
Gate				
V _{GH}	Analog supply voltage – positive	-0.3	V _{GL} +40	V
V _{GL}	Analog supply voltage -- negative	V _{GH} -40	0.3	V
I _{VGH}	Input rush current for V _{DH}	(TBD)	(TBD)	mA
I _{VGL}	Input rush current for V _{DL}	(TBD)	(TBD)	mA
T _{STG}	Storage temperature range	-55	+125	°C

Warning:

If ICs are stressed beyond those listed above “absolute maximum ratings”, they may be permanently destroyed. These are stress ratings only, and functional operation of the device at these or any other condition beyond those indicated under “recommended operating conditions” is not implied. Exposure to absolute maximum rated conditions for extended periods may affect device reliability.

DC CHARACTERISTICS

DIGITAL DC CHARACTERISTICS						
Symbol	Parameter	Conditions	MIN.	TYP.	MAX.	Unit
V _{IO}	IO supply voltage		2.3	3.3	3.6	V
V _{DD}	Supply voltage		2.3	3.3	3.6	V
AV _{DD}	DCDC driver supply voltage	DRVU, DRVD	2.3	3.3	3.6	V
V _{IL}	LOW Level input voltage	Digital input pins	0	--	0.3xV _{DD}	V
V _{IH}	HIGH Level input voltage	Digital input pins	0.7xV _{IO}	--	V _{IO}	V
V _{OH}	HIGH Level output voltage	Digital input pins, I _{OH} =400uA	V _{IO} -0.4	--	--	V
V _{OHD}	HIGH Level output voltage	Digital input pins, I _{OH} =400uA, DRVD, DRVU	AV _{DD} -0.4	--	--	V
V _{OL}	LOW Level Output voltage	Digital input pins, I _{OL} =-400uA	0	--	0.4	V
I _{IN}	Input leakage current	Digital input pins except pull-up, pull-down pin	-1	--	1	uA
R _{IN}	Pull-up/down impedance			200		KΩ
I _{STVDD}	Digital stand-by current	all stopped (power off mode)	--	0 *	0.1 *	uV
I _{VDD}	Digital operating current		--	0.5 *	2.0 *	mV
I _{STVIO}	IO stand-by current	all stopped (power off mode)		0.4 *	1.0 *	uV
I _{VIO}	IO operating current	No load		-- *	0.2 *	mA
I _{STVDD1}	DCDC stand-by current	all stopped (power off mode)		0 *	0.01 *	uA
I _{VDD1}	DCDC operating current	fdcdc=250kHz, No load		-- *	0.05 *	mA
		fdcdc=250kHz, External cap: 415pF, NMOS=340pF		0.5 *	1.0 *	
Top	Operating temperature		-30		85	°C

* TYP. and MAX. values are to be confirmed by design.

ANALOG DC CHARACTERISTICS						
Symbol	Parameter	Conditions	MIN.	TYP.	MAX.	Unit
VDH	Supply Voltage	For source driver/VCOM		10		V
dVDH	Supply voltage dev		-300	0	+300	mV
VDL	Supply Voltage	For source driver/VCOM		-10		V
dVDL	Supply voltage dev		-300	0	+300	mV
I _{dd}	Analog Operating Current	No load,		TBD		mA
V _{vd}	Voltage Deviation of Outputs		--	±20	±35	mV
V _{dr}	Dynamic Range of Output		0.1	--	VDH-0.1	V
VGH-VGL	Voltage Range of VGH - VGL		12		40	V
VGL	VGL voltage Range	For gate driver	-16		-13	V
dVGL	VGL Supply voltage dev		-400	0	+400	mV
VGH	VGH voltage Range	For gate driver	13		VGL+40	V
dVGH	VGH Supply voltage dev		-400	0	+400	mV
I _{stVGH}	Positive HV Stand-by Current (power off mode)	Include VDH power With load	-	0 *	0.01 *	μA
I _{VGH}	Positive HV Operating Current	Include VDH power With load all SD=L VCOM external resistor divider not included	-	0.7 *	1.1 *	mA
I _{VGH}	Positive HV Operating Current	Include VDH power With load all SD=H VCOM external resistor divider not included	-	0.8 *	1.2 *	mA
I _{stVGL}	Negative HV Stand-by Current (power off mode)	Include VDPNS power With load	-	0 *	0.01 *	μA
I _{VGL}	Negative HV Operating Current	Include VDL power With load all SD=L	-	0.8 *	1.2 *	mA
I _{VGL}	Negative HV Operating Current	Include VDL power With load all SD=H	-	0.9 *	1.3 *	mA
I _{stVINT1}	VINT1 Stand-by Current (power off mode)		-	0 *	0.01 *	μA
I _{VINT1}	VINT1 Operating Current		-	-- *	0.3 *	mA

* TYP. and MAX. values are to be confirmed by design.

AC CHARACTERISTICS

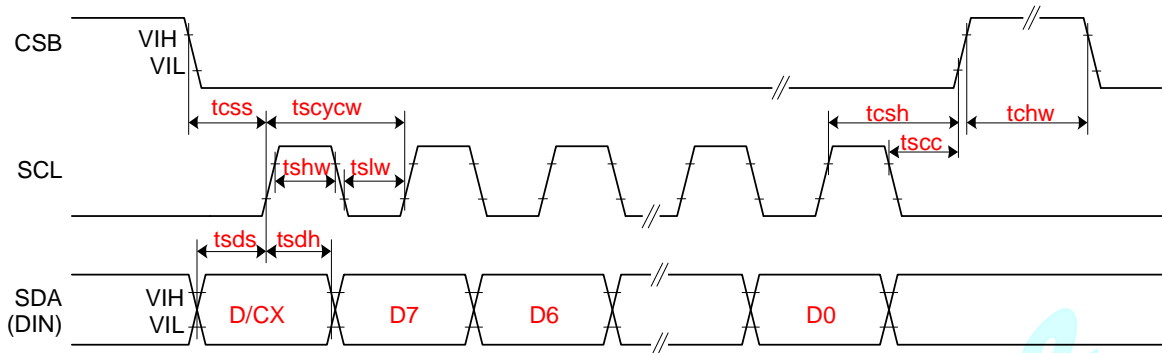

3-wire Serial Interface – Write

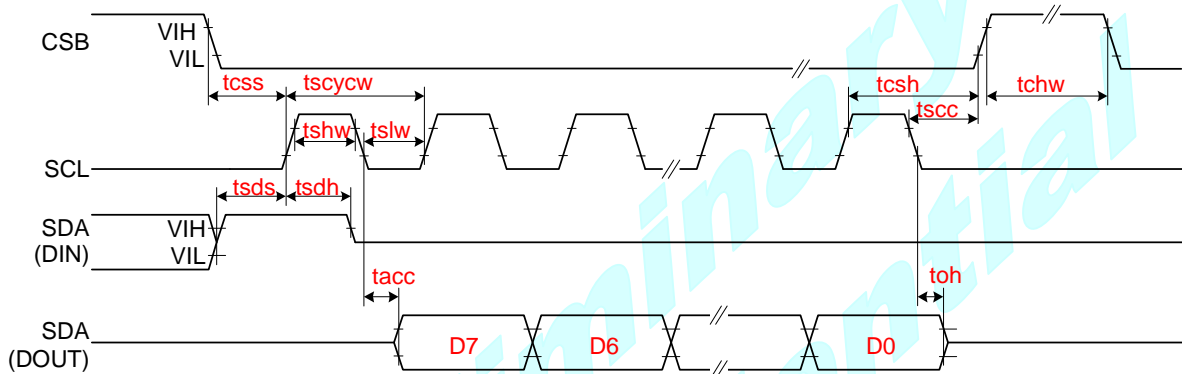

3-wire Serial Interface – Read

SYMBOL	SIGNAL		MIN.	TYP.	MAX.	UNIT
SERIAL COMMUNICATION						
tCSS	CSB	Chip select setup time	60			ns
tCSH		Chip select hold time	65			ns
tSCC		Chip select setup time	20			ns
tCHW		Chip select setup time	40			ns
tSCYCW	SCL	Serial clock cycle (Write)	100			ns
tSHW		SCL "H" pulse width (Write)	35			ns
tSLW		SCL "L" pulse width (Write)	35			ns
tSCYCR		Serial clock cycle (Read)	150			ns
tSHR		SCL "H" pulse width (Read)	60			ns
tSLR		SCL "L" pulse width (Read)	60			ns
tSDS	SDA (DIN) (DOUT)	Data setup time	30			ns
tSDH		Data hold time	30			ns
tACC		Access time	10			ns
tOH		Output disable time	15			ns

SYMBOL	SIGNAL			MIN.	TYP.	MAX.	UNIT
DRIVER							
trS		Source driver rise time	99% final value		5		us
tFS		Source driver fall time			5		us
trG		Gate driver rise time	99% final value		5		us
tFG		Gate driver fall time			5		us
trCOM		VCOM rise time	99% final value		1		ms
tFCOM		VCOM fall time			1		ms
RC LOADING							
RL_S		Source driver output loading			TBD		K Ω
CL_S					TBD		pf
RL_G		Gate driver output loading			TBD		KΩ
CL_G					TBD		pf
RL_com		VCOM output loading			TBD		Ω
CL_com					TBD		pf

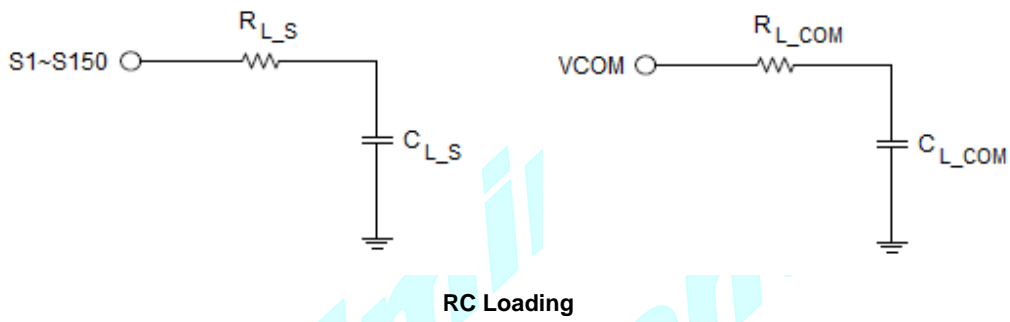

Preliminary
Confidential

PHYSICAL DIMENSIONS

Die Size:	$(9531 \mu\text{M} \pm 40\mu\text{M}) \times (981 \mu\text{M} \pm 40\mu\text{M})$
Die Thickness:	$280 \mu\text{M} \pm 20\mu\text{M}$ (Polish)
Die TTV:	$(D_{\text{MAX}} - D_{\text{MIN}})$ within die $\leq 2\mu\text{M}$
Bump Height:	$12 \mu\text{M} \pm 3\mu\text{M}$ $(H_{\text{MAX}} - H_{\text{MIN}})$ within die $\leq 2\mu\text{M}$
Hardness:	$65 \text{ Hv} \pm 15\text{Hv}$
Bump Size:	$12 \mu\text{M} \times 100 \mu\text{M} \pm 2\mu\text{M}$
Bump Area:	$1200 \mu\text{M}^2$
Bump Pitch:	$26 \mu\text{M}$
Bump Gap:	$14 \mu\text{M} \pm 3\mu\text{M}$
Shear:	$\geq 5\text{g/Mil}^2$
Coordinate origin:	Chip center
Pad reference:	Pad center

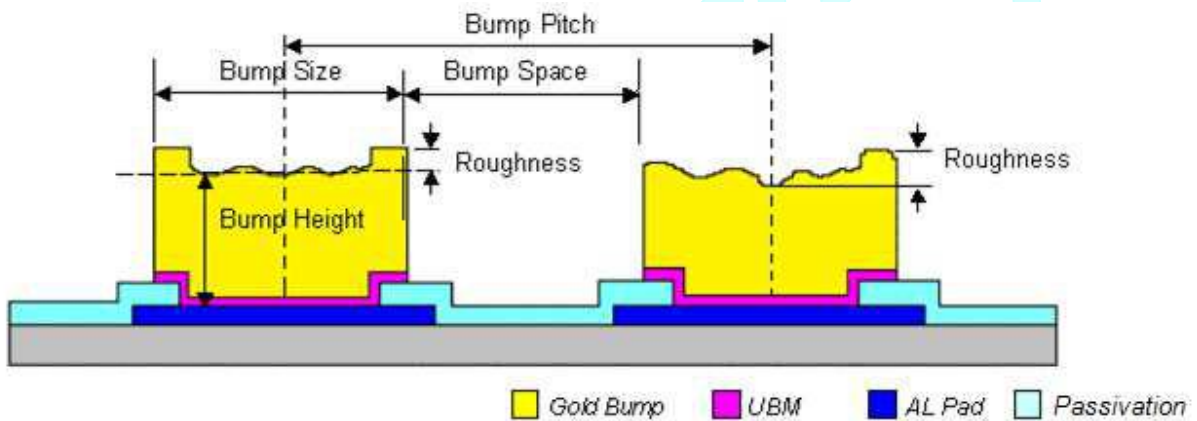

Bump Height Coplanarity within Die

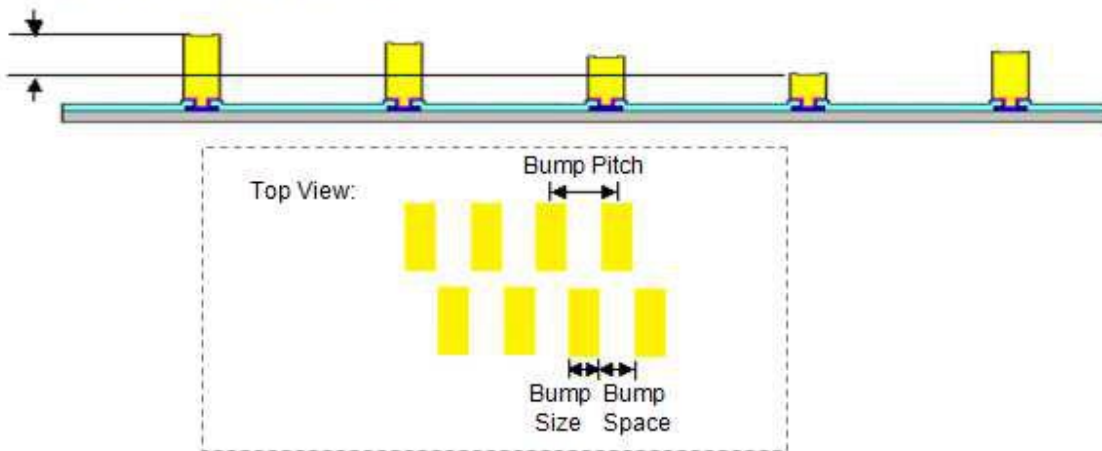

ALIGNMENT MARK INFORMATION

Location:

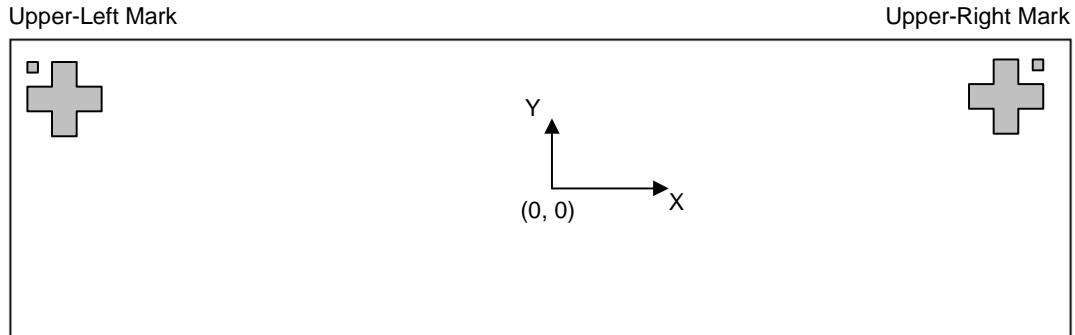

Shapes and Points:

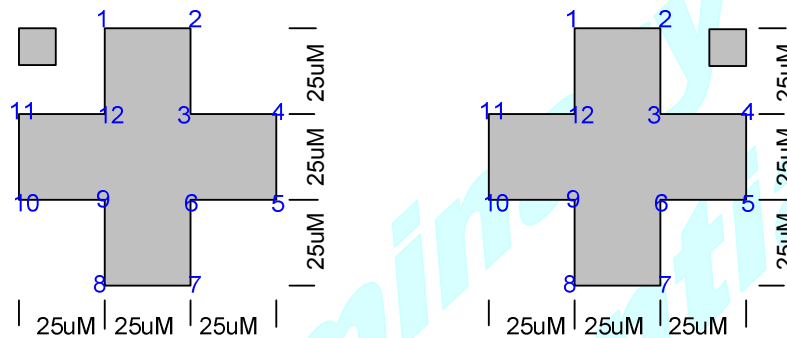

Point Coordinates:

Point	Upper-Left Mark		Upper-Right Mark	
	X	Y	X	Y
Center	-4665	390	4665	390
1	-4675	420	4655	420
2	-4655	420	4675	420
3	-4655	400	4675	400
4	-4635	400	4695	400
5	-4635	380	4695	380
6	-4655	380	4675	380
7	-4655	360	4675	360
8	-4675	360	4655	360
9	-4675	380	4655	380
10	-4695	380	4635	380
11	-4695	400	4635	400
12	-4675	400	4655	400

PAD COORDINATES

No.	Name	X	Y	W	H
1	NC	-4646	-398	28	70
2	VCOM	-4600	-398	28	70
3	VCOM	-4554	-398	28	70
4	VCOM	-4508	-398	28	70
5	VCOM	-4462	-398	28	70
6	VCOM	-4416	-398	28	70
7	VCOM	-4370	-398	28	70
8	VCOM	-4324	-398	28	70
9	VCOM	-4278	-398	28	70
10	VDM	-4232	-398	28	70
11	VGL	-4186	-398	28	70
12	VGL	-4140	-398	28	70
13	VGL	-4094	-398	28	70
14	VGL	-4048	-398	28	70
15	VGL	-4002	-398	28	70
16	VGL	-3956	-398	28	70
17	VGL	-3910	-398	28	70
18	VGL	-3864	-398	28	70
19	VGL	-3818	-398	28	70
20	VGL	-3772	-398	28	70
21	VGL	-3726	-398	28	70
22	VGL	-3680	-398	28	70
23	VGL	-3634	-398	28	70
24	VGL	-3588	-398	28	70
25	VGL	-3542	-398	28	70
26	VGL	-3496	-398	28	70
27	GND	-3450	-398	28	70
28	VSL	-3404	-398	28	70
29	VSL	-3358	-398	28	70
30	VSL	-3312	-398	28	70
31	VSL	-3266	-398	28	70
32	VSL	-3220	-398	28	70
33	VSL	-3174	-398	28	70
34	VSL	-3128	-398	28	70
35	VSL	-3082	-398	28	70
36	VSL	-3036	-398	28	70
37	VSL	-2990	-398	28	70
38	GND	-2944	-398	28	70
39	VGH	-2898	-398	28	70
40	VGH	-2852	-398	28	70
41	VGH	-2806	-398	28	70
42	VGH	-2760	-398	28	70
43	VGH	-2714	-398	28	70
44	VGH	-2668	-398	28	70
45	VGH	-2622	-398	28	70
46	VGH	-2576	-398	28	70
47	VGH	-2530	-398	28	70
48	VGH	-2484	-398	28	70
49	VGH	-2438	-398	28	70
50	VGH	-2392	-398	28	70
51	GND	-2346	-398	28	70
52	VSH	-2300	-398	28	70
53	VSH	-2254	-398	28	70
54	VSH	-2208	-398	28	70
55	VSH	-2162	-398	28	70
56	VSH	-2116	-398	28	70
57	VSH	-2070	-398	28	70
58	VSH	-2024	-398	28	70

No.	Name	X	Y	W	H
59	VSH	-1978	-398	28	70
60	VSH	-1932	-398	28	70
61	VSH	-1886	-398	28	70
62	GND	-1840	-398	28	70
63	VPP	-1794	-398	28	70
64	VPP	-1748	-398	28	70
65	VPP	-1702	-398	28	70
66	VPP	-1656	-398	28	70
67	VPP	-1610	-398	28	70
68	VPP	-1564	-398	28	70
69	VDDD	-1518	-398	28	70
70	VDDD	-1472	-398	28	70
71	VDDD	-1426	-398	28	70
72	VDDD	-1380	-398	28	70
73	VDDDO	-1334	-398	28	70
74	VDDDO	-1288	-398	28	70
75	VDDDO	-1242	-398	28	70
76	VDDDO	-1196	-398	28	70
77	VDM	-1150	-398	28	70
78	VDM	-1104	-398	28	70
79	GND	-1058	-398	28	70
80	GND	-1012	-398	28	70
81	GND	-966	-398	28	70
82	GND	-920	-398	28	70
83	GND	-874	-398	28	70
84	GND	-828	-398	28	70
85	GND	-782	-398	28	70
86	GND	-736	-398	28	70
87	GND	-690	-398	28	70
88	GND	-644	-398	28	70
89	GND	-598	-398	28	70
90	GND	-552	-398	28	70
91	GND	-506	-398	28	70
92	GND	-460	-398	28	70
93	GND	-414	-398	28	70
94	GND	-368	-398	28	70
95	GND	-322	-398	28	70
96	GND	-276	-398	28	70
97	GND	-230	-398	28	70
98	GND	-184	-398	28	70
99	GND	-138	-398	28	70
100	GND	-92	-398	28	70
101	VDDA	-46	-398	28	70
102	VDDA	0	-398	28	70
103	VDDA	46	-398	28	70
104	VDDA	92	-398	28	70
105	VDDA	138	-398	28	70
106	VDDA	184	-398	28	70
107	VDDA	230	-398	28	70
108	VDDA	276	-398	28	70
109	VDDA	322	-398	28	70
110	VDDA	368	-398	28	70
111	VDD	414	-398	28	70
112	VDD	460	-398	28	70
113	VDD	506	-398	28	70
114	VDD	552	-398	28	70
115	VDD	598	-398	28	70
116	VDD	644	-398	28	70

No.	Name	X	Y	W	H
117	VDD	690	-398	28	70
118	TEST1	736	-398	28	70
119	TEST2	782	-398	28	70
120	VDDIO	828	-398	28	70
121	VDDIO	874	-398	28	70
122	VDDIO	920	-398	28	70
123	VDDIO	966	-398	28	70
124	TEST3	1012	-398	28	70
125	DUMMY	1058	-398	28	70
126	DUMMY	1104	-398	28	70
127	DUMMY	1150	-398	28	70
128	DUMMY	1196	-398	28	70
129	DUMMY	1242	-398	28	70
130	SDA	1288	-398	28	70
131	SCL	1334	-398	28	70
132	GND	1380	-398	28	70
133	CSB	1426	-398	28	70
134	VDDIO	1472	-398	28	70
135	DUMMY	1518	-398	28	70
136	GND	1564	-398	28	70
137	DC	1610	-398	28	70
138	VDDIO	1656	-398	28	70
139	DUMMY	1702	-398	28	70
140	GND	1748	-398	28	70
141	RST_N	1794	-398	28	70
142	BUSY_N	1840	-398	28	70
143	CL	1886	-398	28	70
144	VDDIO	1932	-398	28	70
145	VSYNC	1978	-398	28	70
146	GND	2024	-398	28	70
147	DUMMY	2070	-398	28	70
148	VDDIO	2116	-398	28	70
149	BS	2162	-398	28	70
150	GND	2208	-398	28	70
151	DUMMY	2254	-398	28	70
152	VDDIO	2300	-398	28	70
153	TESTVDD	2346	-398	28	70
154	GND	2392	-398	28	70
155	MS	2438	-398	28	70
156	VDDIO	2484	-398	28	70
157	TSDA	2530	-398	28	70
158	TSDA	2576	-398	28	70
159	TSCL	2622	-398	28	70
160	TSCL	2668	-398	28	70
161	TEST4	2714	-398	28	70
162	TEST5	2760	-398	28	70
163	TEST6	2806	-398	28	70
164	TEST7	2852	-398	28	70
165	VDHR	2898	-398	28	70
166	VDHR	2944	-398	28	70
167	VDHR	2990	-398	28	70
168	VDHR	3036	-398	28	70
169	VDHR	3082	-398	28	70
170	VDHR	3128	-398	28	70
171	VDHR	3174	-398	28	70
172	VDHR	3220	-398	28	70
173	DUMMY	3266	-398	28	70
174	DUMMY	3312	-398	28	70
175	DUMMY	3358	-398	28	70
176	DUMMY	3404	-398	28	70

No.	Name	X	Y	W	H
177	DUMMY	3450	-398	28	70
178	DUMMY	3496	-398	28	70
179	GND	3542	-398	28	70
180	FB	3588	-398	28	70
181	FB	3634	-398	28	70
182	GND	3680	-398	28	70
183	RESE	3726	-398	28	70
184	RESE	3772	-398	28	70
185	GND	3818	-398	28	70
186	GDR	3864	-398	28	70
187	GDR	3910	-398	28	70
188	GDR	3956	-398	28	70
189	GDR	4002	-398	28	70
190	GDR	4048	-398	28	70
191	GDR	4094	-398	28	70
192	GDR	4140	-398	28	70
193	GDR	4186	-398	28	70
194	VDM	4232	-398	28	70
195	VCOM	4278	-398	28	70
196	VCOM	4324	-398	28	70
197	VCOM	4370	-398	28	70
198	VCOM	4416	-398	28	70
199	VCOM	4462	-398	28	70
200	VCOM	4508	-398	28	70
201	VCOM	4554	-398	28	70
202	VCOM	4600	-398	28	70
203	NC	4646	-398	28	70
204	NC	4540	313.5	18	75
205	NC	4519	413.5	18	75
206	NC	4498	313.5	18	75
207	NC	4477	413.5	18	75
208	NC	4456	313.5	18	75
209	NC	4435	413.5	18	75
210	G<0>	4414	313.5	18	75
211	G<2>	4393	413.5	18	75
212	G<4>	4372	313.5	18	75
213	G<6>	4351	413.5	18	75
214	G<8>	4330	313.5	18	75
215	G<10>	4309	413.5	18	75
216	G<12>	4288	313.5	18	75
217	G<14>	4267	413.5	18	75
218	G<16>	4246	313.5	18	75
219	G<18>	4225	413.5	18	75
220	G<20>	4204	313.5	18	75
221	G<22>	4183	413.5	18	75
222	G<24>	4162	313.5	18	75
223	G<26>	4141	413.5	18	75
224	G<28>	4120	313.5	18	75
225	G<30>	4099	413.5	18	75
226	G<32>	4078	313.5	18	75
227	G<34>	4057	413.5	18	75
228	G<36>	4036	313.5	18	75
229	G<38>	4015	413.5	18	75
230	G<40>	3994	313.5	18	75
231	G<42>	3973	413.5	18	75
232	G<44>	3952	313.5	18	75
233	G<46>	3931	413.5	18	75
234	G<48>	3910	313.5	18	75
235	G<50>	3889	413.5	18	75
236	G<52>	3868	313.5	18	75

No.	Name	X	Y	W	H
237	G<54>	3847	413.5	18	75
238	G<56>	3826	313.5	18	75
239	G<58>	3805	413.5	18	75
240	G<60>	3784	313.5	18	75
241	G<62>	3763	413.5	18	75
242	G<64>	3742	313.5	18	75
243	G<66>	3721	413.5	18	75
244	G<68>	3700	313.5	18	75
245	G<70>	3679	413.5	18	75
246	G<72>	3658	313.5	18	75
247	G<74>	3637	413.5	18	75
248	G<76>	3616	313.5	18	75
249	G<78>	3595	413.5	18	75
250	G<80>	3574	313.5	18	75
251	G<82>	3553	413.5	18	75
252	G<84>	3532	313.5	18	75
253	G<86>	3511	413.5	18	75
254	G<88>	3490	313.5	18	75
255	G<90>	3469	413.5	18	75
256	G<92>	3448	313.5	18	75
257	G<94>	3427	413.5	18	75
258	G<96>	3406	313.5	18	75
259	G<98>	3385	413.5	18	75
260	G<100>	3364	313.5	18	75
261	G<102>	3343	413.5	18	75
262	G<104>	3322	313.5	18	75
263	G<106>	3301	413.5	18	75
264	G<108>	3280	313.5	18	75
265	G<110>	3259	413.5	18	75
266	G<112>	3238	313.5	18	75
267	G<114>	3217	413.5	18	75
268	G<116>	3196	313.5	18	75
269	G<118>	3175	413.5	18	75
270	G<120>	3154	313.5	18	75
271	G<122>	3133	413.5	18	75
272	G<124>	3112	313.5	18	75
273	G<126>	3091	413.5	18	75
274	G<128>	3070	313.5	18	75
275	G<130>	3049	413.5	18	75
276	G<132>	3028	313.5	18	75
277	G<134>	3007	413.5	18	75
278	G<136>	2986	313.5	18	75
279	G<138>	2965	413.5	18	75
280	G<140>	2944	313.5	18	75
281	G<142>	2923	413.5	18	75
282	G<144>	2902	313.5	18	75
283	G<146>	2881	413.5	18	75
284	G<148>	2860	313.5	18	75
285	G<150>	2839	413.5	18	75
286	G<152>	2818	313.5	18	75
287	G<154>	2797	413.5	18	75
288	G<156>	2776	313.5	18	75
289	G<158>	2755	413.5	18	75
290	G<160>	2734	313.5	18	75
291	G<162>	2713	413.5	18	75
292	G<164>	2692	313.5	18	75
293	G<166>	2671	413.5	18	75
294	G<168>	2650	313.5	18	75
295	G<170>	2629	413.5	18	75
296	G<172>	2608	313.5	18	75

No.	Name	X	Y	W	H
297	G<174>	2587	413.5	18	75
298	G<176>	2566	313.5	18	75
299	G<178>	2545	413.5	18	75
300	G<180>	2524	313.5	18	75
301	G<182>	2503	413.5	18	75
302	G<184>	2482	313.5	18	75
303	G<186>	2461	413.5	18	75
304	G<188>	2440	313.5	18	75
305	G<190>	2419	413.5	18	75
306	G<192>	2398	313.5	18	75
307	G<194>	2377	413.5	18	75
308	G<196>	2356	313.5	18	75
309	G<198>	2335	413.5	18	75
310	G<200>	2314	313.5	18	75
311	G<202>	2293	413.5	18	75
312	G<204>	2272	313.5	18	75
313	G<206>	2251	413.5	18	75
314	G<208>	2230	313.5	18	75
315	G<210>	2209	413.5	18	75
316	G<212>	2188	313.5	18	75
317	G<214>	2167	413.5	18	75
318	G<216>	2146	313.5	18	75
319	G<218>	2125	413.5	18	75
320	G<220>	2104	313.5	18	75
321	G<222>	2083	413.5	18	75
322	G<224>	2062	313.5	18	75
323	G<226>	2041	413.5	18	75
324	G<228>	2020	313.5	18	75
325	G<230>	1999	413.5	18	75
326	G<232>	1978	313.5	18	75
327	G<234>	1957	413.5	18	75
328	G<236>	1936	313.5	18	75
329	G<238>	1915	413.5	18	75
330	G<240>	1894	313.5	18	75
331	G<242>	1873	413.5	18	75
332	G<244>	1852	313.5	18	75
333	G<246>	1831	413.5	18	75
334	G<248>	1810	313.5	18	75
335	G<250>	1789	413.5	18	75
336	G<252>	1768	313.5	18	75
337	G<254>	1747	413.5	18	75
338	G<256>	1726	313.5	18	75
339	G<258>	1705	413.5	18	75
340	G<260>	1684	313.5	18	75
341	G<262>	1663	413.5	18	75
342	G<264>	1642	313.5	18	75
343	G<266>	1621	413.5	18	75
344	G<268>	1600	313.5	18	75
345	G<270>	1579	413.5	18	75
346	G<272>	1558	313.5	18	75
347	G<274>	1537	413.5	18	75
348	G<276>	1516	313.5	18	75
349	G<278>	1495	413.5	18	75
350	G<280>	1474	313.5	18	75
351	G<282>	1453	413.5	18	75
352	G<284>	1432	313.5	18	75
353	G<286>	1411	413.5	18	75
354	G<288>	1390	313.5	18	75
355	G<290>	1369	413.5	18	75
356	G<292>	1348	313.5	18	75

No.	Name	X	Y	W	H
357	G<294>	1327	413.5	18	75
358	NC	1306	313.5	18	75
359	NC	1285	413.5	18	75
360	NC	1264	313.5	18	75
361	NC	1243	413.5	18	75
362	NC	1222	313.5	18	75
363	NC	1201	413.5	18	75
364	NC	1180	313.5	18	75
365	NC	1072.5	420	12	100
366	NC	1059.5	301	12	100
367	VBD<1>	1046.5	420	12	100
368	S<0>	1033.5	301	12	100
369	S<1>	1020.5	420	12	100
370	S<2>	1007.5	301	12	100
371	S<3>	994.5	420	12	100
372	S<4>	981.5	301	12	100
373	S<5>	968.5	420	12	100
374	S<6>	955.5	301	12	100
375	S<7>	942.5	420	12	100
376	S<8>	929.5	301	12	100
377	S<9>	916.5	420	12	100
378	S<10>	903.5	301	12	100
379	S<11>	890.5	420	12	100
380	S<12>	877.5	301	12	100
381	S<13>	864.5	420	12	100
382	S<14>	851.5	301	12	100
383	S<15>	838.5	420	12	100
384	S<16>	825.5	301	12	100
385	S<17>	812.5	420	12	100
386	S<18>	799.5	301	12	100
387	S<19>	786.5	420	12	100
388	S<20>	773.5	301	12	100
389	S<21>	760.5	420	12	100
390	S<22>	747.5	301	12	100
391	S<23>	734.5	420	12	100
392	S<24>	721.5	301	12	100
393	S<25>	708.5	420	12	100
394	S<26>	695.5	301	12	100
395	S<27>	682.5	420	12	100
396	S<28>	669.5	301	12	100
397	S<29>	656.5	420	12	100
398	S<30>	643.5	301	12	100
399	S<31>	630.5	420	12	100
400	S<32>	617.5	301	12	100
401	S<33>	604.5	420	12	100
402	S<34>	591.5	301	12	100
403	S<35>	578.5	420	12	100
404	S<36>	565.5	301	12	100
405	S<37>	552.5	420	12	100
406	S<38>	539.5	301	12	100
407	S<39>	526.5	420	12	100
408	S<40>	513.5	301	12	100
409	S<41>	500.5	420	12	100
410	S<42>	487.5	301	12	100
411	S<43>	474.5	420	12	100
412	S<44>	461.5	301	12	100
413	S<45>	448.5	420	12	100
414	S<46>	435.5	301	12	100
415	S<47>	422.5	420	12	100
416	S<48>	409.5	301	12	100

No.	Name	X	Y	W	H
417	S<49>	396.5	420	12	100
418	S<50>	383.5	301	12	100
419	S<51>	370.5	420	12	100
420	S<52>	357.5	301	12	100
421	S<53>	344.5	420	12	100
422	S<54>	331.5	301	12	100
423	S<55>	318.5	420	12	100
424	S<56>	305.5	301	12	100
425	S<57>	292.5	420	12	100
426	S<58>	279.5	301	12	100
427	S<59>	266.5	420	12	100
428	S<60>	253.5	301	12	100
429	S<61>	240.5	420	12	100
430	S<62>	227.5	301	12	100
431	S<63>	214.5	420	12	100
432	S<64>	201.5	301	12	100
433	S<65>	188.5	420	12	100
434	S<66>	175.5	301	12	100
435	S<67>	162.5	420	12	100
436	S<68>	149.5	301	12	100
437	S<69>	136.5	420	12	100
438	S<70>	123.5	301	12	100
439	S<71>	110.5	420	12	100
440	S<72>	97.5	301	12	100
441	S<73>	84.5	420	12	100
442	S<74>	71.5	301	12	100
443	S<75>	58.5	420	12	100
444	S<76>	45.5	301	12	100
445	S<77>	32.5	420	12	100
446	S<78>	19.5	301	12	100
447	S<79>	6.5	420	12	100
448	S<80>	-6.5	301	12	100
449	S<81>	-19.5	420	12	100
450	S<82>	-32.5	301	12	100
451	S<83>	-45.5	420	12	100
452	S<84>	-58.5	301	12	100
453	S<85>	-71.5	420	12	100
454	S<86>	-84.5	301	12	100
455	S<87>	-97.5	420	12	100
456	S<88>	-110.5	301	12	100
457	S<89>	-123.5	420	12	100
458	S<90>	-136.5	301	12	100
459	S<91>	-149.5	420	12	100
460	S<92>	-162.5	301	12	100
461	S<93>	-175.5	420	12	100
462	S<94>	-188.5	301	12	100
463	S<95>	-201.5	420	12	100
464	S<96>	-214.5	301	12	100
465	S<97>	-227.5	420	12	100
466	S<98>	-240.5	301	12	100
467	S<99>	-253.5	420	12	100
468	S<100>	-266.5	301	12	100
469	S<101>	-279.5	420	12	100
470	S<102>	-292.5	301	12	100
471	S<103>	-305.5	420	12	100
472	S<104>	-318.5	301	12	100
473	S<105>	-331.5	420	12	100
474	S<106>	-344.5	301	12	100
475	S<107>	-357.5	420	12	100
476	S<108>	-370.5	301	12	100

No.	Name	X	Y	W	H
477	S<109>	-383.5	420	12	100
478	S<110>	-396.5	301	12	100
479	S<111>	-409.5	420	12	100
480	S<112>	-422.5	301	12	100
481	S<113>	-435.5	420	12	100
482	S<114>	-448.5	301	12	100
483	S<115>	-461.5	420	12	100
484	S<116>	-474.5	301	12	100
485	S<117>	-487.5	420	12	100
486	S<118>	-500.5	301	12	100
487	S<119>	-513.5	420	12	100
488	S<120>	-526.5	301	12	100
489	S<121>	-539.5	420	12	100
490	S<122>	-552.5	301	12	100
491	S<123>	-565.5	420	12	100
492	S<124>	-578.5	301	12	100
493	S<125>	-591.5	420	12	100
494	S<126>	-604.5	301	12	100
495	S<127>	-617.5	420	12	100
496	S<128>	-630.5	301	12	100
497	S<129>	-643.5	420	12	100
498	S<130>	-656.5	301	12	100
499	S<131>	-669.5	420	12	100
500	S<132>	-682.5	301	12	100
501	S<133>	-695.5	420	12	100
502	S<134>	-708.5	301	12	100
503	S<135>	-721.5	420	12	100
504	S<136>	-734.5	301	12	100
505	S<137>	-747.5	420	12	100
506	S<138>	-760.5	301	12	100
507	S<139>	-773.5	420	12	100
508	S<140>	-786.5	301	12	100
509	S<141>	-799.5	420	12	100
510	S<142>	-812.5	301	12	100
511	S<143>	-825.5	420	12	100
512	S<144>	-838.5	301	12	100
513	S<145>	-851.5	420	12	100
514	S<146>	-864.5	301	12	100
515	S<147>	-877.5	420	12	100
516	S<148>	-890.5	301	12	100
517	S<149>	-903.5	420	12	100
518	S<150>	-916.5	301	12	100
519	S<151>	-929.5	420	12	100
520	S<152>	-942.5	301	12	100
521	S<153>	-955.5	420	12	100
522	S<154>	-968.5	301	12	100
523	S<155>	-981.5	420	12	100
524	S<156>	-994.5	301	12	100
525	S<157>	-1007.5	420	12	100
526	S<158>	-1020.5	301	12	100
527	S<159>	-1033.5	420	12	100
528	VBD<2>	-1046.5	301	12	100
529	NC	-1059.5	420	12	100
530	NC	-1072.5	301	12	100
531	NC	-1180	413.5	18	75
532	NC	-1201	313.5	18	75
533	NC	-1222	413.5	18	75
534	NC	-1243	313.5	18	75
535	NC	-1264	413.5	18	75
536	NC	-1285	313.5	18	75

No.	Name	X	Y	W	H
537	NC	-1306	413.5	18	75
538	G<295>	-1327	313.5	18	75
539	G<293>	-1348	413.5	18	75
540	G<291>	-1369	313.5	18	75
541	G<289>	-1390	413.5	18	75
542	G<287>	-1411	313.5	18	75
543	G<285>	-1432	413.5	18	75
544	G<283>	-1453	313.5	18	75
545	G<281>	-1474	413.5	18	75
546	G<279>	-1495	313.5	18	75
547	G<277>	-1516	413.5	18	75
548	G<275>	-1537	313.5	18	75
549	G<273>	-1558	413.5	18	75
550	G<271>	-1579	313.5	18	75
551	G<269>	-1600	413.5	18	75
552	G<267>	-1621	313.5	18	75
553	G<265>	-1642	413.5	18	75
554	G<263>	-1663	313.5	18	75
555	G<261>	-1684	413.5	18	75
556	G<259>	-1705	313.5	18	75
557	G<257>	-1726	413.5	18	75
558	G<255>	-1747	313.5	18	75
559	G<253>	-1768	413.5	18	75
560	G<251>	-1789	313.5	18	75
561	G<249>	-1810	413.5	18	75
562	G<247>	-1831	313.5	18	75
563	G<245>	-1852	413.5	18	75
564	G<243>	-1873	313.5	18	75
565	G<241>	-1894	413.5	18	75
566	G<239>	-1915	313.5	18	75
567	G<237>	-1936	413.5	18	75
568	G<235>	-1957	313.5	18	75
569	G<233>	-1978	413.5	18	75
570	G<231>	-1999	313.5	18	75
571	G<229>	-2020	413.5	18	75
572	G<227>	-2041	313.5	18	75
573	G<225>	-2062	413.5	18	75
574	G<223>	-2083	313.5	18	75
575	G<221>	-2104	413.5	18	75
576	G<219>	-2125	313.5	18	75
577	G<217>	-2146	413.5	18	75
578	G<215>	-2167	313.5	18	75
579	G<213>	-2188	413.5	18	75
580	G<211>	-2209	313.5	18	75
581	G<209>	-2230	413.5	18	75
582	G<207>	-2251	313.5	18	75
583	G<205>	-2272	413.5	18	75
584	G<203>	-2293	313.5	18	75
585	G<201>	-2314	413.5	18	75
586	G<199>	-2335	313.5	18	75
587	G<197>	-2356	413.5	18	75
588	G<195>	-2377	313.5	18	75
589	G<193>	-2398	413.5	18	75
590	G<191>	-2419	313.5	18	75
591	G<189>	-2440	413.5	18	75
592	G<187>	-2461	313.5	18	75
593	G<185>	-2482	413.5	18	75
594	G<183>	-2503	313.5	18	75
595	G<181>	-2524	413.5	18	75
596	G<179>	-2545	313.5	18	75

No.	Name	X	Y	W	H
597	G<177>	-2566	413.5	18	75
598	G<175>	-2587	313.5	18	75
599	G<173>	-2608	413.5	18	75
600	G<171>	-2629	313.5	18	75
601	G<169>	-2650	413.5	18	75
602	G<167>	-2671	313.5	18	75
603	G<165>	-2692	413.5	18	75
604	G<163>	-2713	313.5	18	75
605	G<161>	-2734	413.5	18	75
606	G<159>	-2755	313.5	18	75
607	G<157>	-2776	413.5	18	75
608	G<155>	-2797	313.5	18	75
609	G<153>	-2818	413.5	18	75
610	G<151>	-2839	313.5	18	75
611	G<149>	-2860	413.5	18	75
612	G<147>	-2881	313.5	18	75
613	G<145>	-2902	413.5	18	75
614	G<143>	-2923	313.5	18	75
615	G<141>	-2944	413.5	18	75
616	G<139>	-2965	313.5	18	75
617	G<137>	-2986	413.5	18	75
618	G<135>	-3007	313.5	18	75
619	G<133>	-3028	413.5	18	75
620	G<131>	-3049	313.5	18	75
621	G<129>	-3070	413.5	18	75
622	G<127>	-3091	313.5	18	75
623	G<125>	-3112	413.5	18	75
624	G<123>	-3133	313.5	18	75
625	G<121>	-3154	413.5	18	75
626	G<119>	-3175	313.5	18	75
627	G<117>	-3196	413.5	18	75
628	G<115>	-3217	313.5	18	75
629	G<113>	-3238	413.5	18	75
630	G<111>	-3259	313.5	18	75
631	G<109>	-3280	413.5	18	75
632	G<107>	-3301	313.5	18	75
633	G<105>	-3322	413.5	18	75
634	G<103>	-3343	313.5	18	75
635	G<101>	-3364	413.5	18	75
636	G<99>	-3385	313.5	18	75
637	G<97>	-3406	413.5	18	75
638	G<95>	-3427	313.5	18	75
639	G<93>	-3448	413.5	18	75
640	G<91>	-3469	313.5	18	75
641	G<89>	-3490	413.5	18	75
642	G<87>	-3511	313.5	18	75
643	G<85>	-3532	413.5	18	75
644	G<83>	-3553	313.5	18	75
645	G<81>	-3574	413.5	18	75

No.	Name	X	Y	W	H
646	G<79>	-3595	313.5	18	75
647	G<77>	-3616	413.5	18	75
648	G<75>	-3637	313.5	18	75
649	G<73>	-3658	413.5	18	75
650	G<71>	-3679	313.5	18	75
651	G<69>	-3700	413.5	18	75
652	G<67>	-3721	313.5	18	75
653	G<65>	-3742	413.5	18	75
654	G<63>	-3763	313.5	18	75
655	G<61>	-3784	413.5	18	75
656	G<59>	-3805	313.5	18	75
657	G<57>	-3826	413.5	18	75
658	G<55>	-3847	313.5	18	75
659	G<53>	-3868	413.5	18	75
660	G<51>	-3889	313.5	18	75
661	G<49>	-3910	413.5	18	75
662	G<47>	-3931	313.5	18	75
663	G<45>	-3952	413.5	18	75
664	G<43>	-3973	313.5	18	75
665	G<41>	-3994	413.5	18	75
666	G<39>	-4015	313.5	18	75
667	G<37>	-4036	413.5	18	75
668	G<35>	-4057	313.5	18	75
669	G<33>	-4078	413.5	18	75
670	G<31>	-4099	313.5	18	75
671	G<29>	-4120	413.5	18	75
672	G<27>	-4141	313.5	18	75
673	G<25>	-4162	413.5	18	75
674	G<23>	-4183	313.5	18	75
675	G<21>	-4204	413.5	18	75
676	G<19>	-4225	313.5	18	75
677	G<17>	-4246	413.5	18	75
678	G<15>	-4267	313.5	18	75
679	G<13>	-4288	413.5	18	75
680	G<11>	-4309	313.5	18	75
681	G<9>	-4330	413.5	18	75
682	G<7>	-4351	313.5	18	75
683	G<5>	-4372	413.5	18	75
684	G<3>	-4393	313.5	18	75
685	G<1>	-4414	413.5	18	75
686	NC	-4435	313.5	18	75
687	NC	-4456	413.5	18	75
688	NC	-4477	313.5	18	75
689	NC	-4498	413.5	18	75
690	NC	-4519	313.5	18	75
691	NC	-4540	413.5	18	75

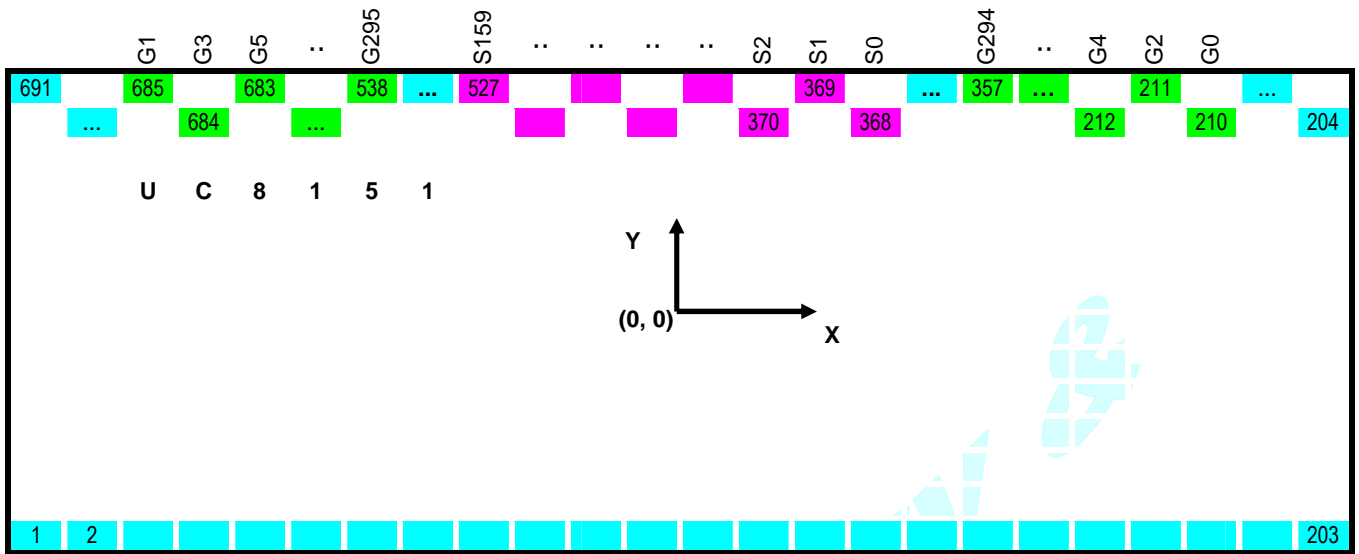

Preliminary
Confidential

TRAY INFORMATION

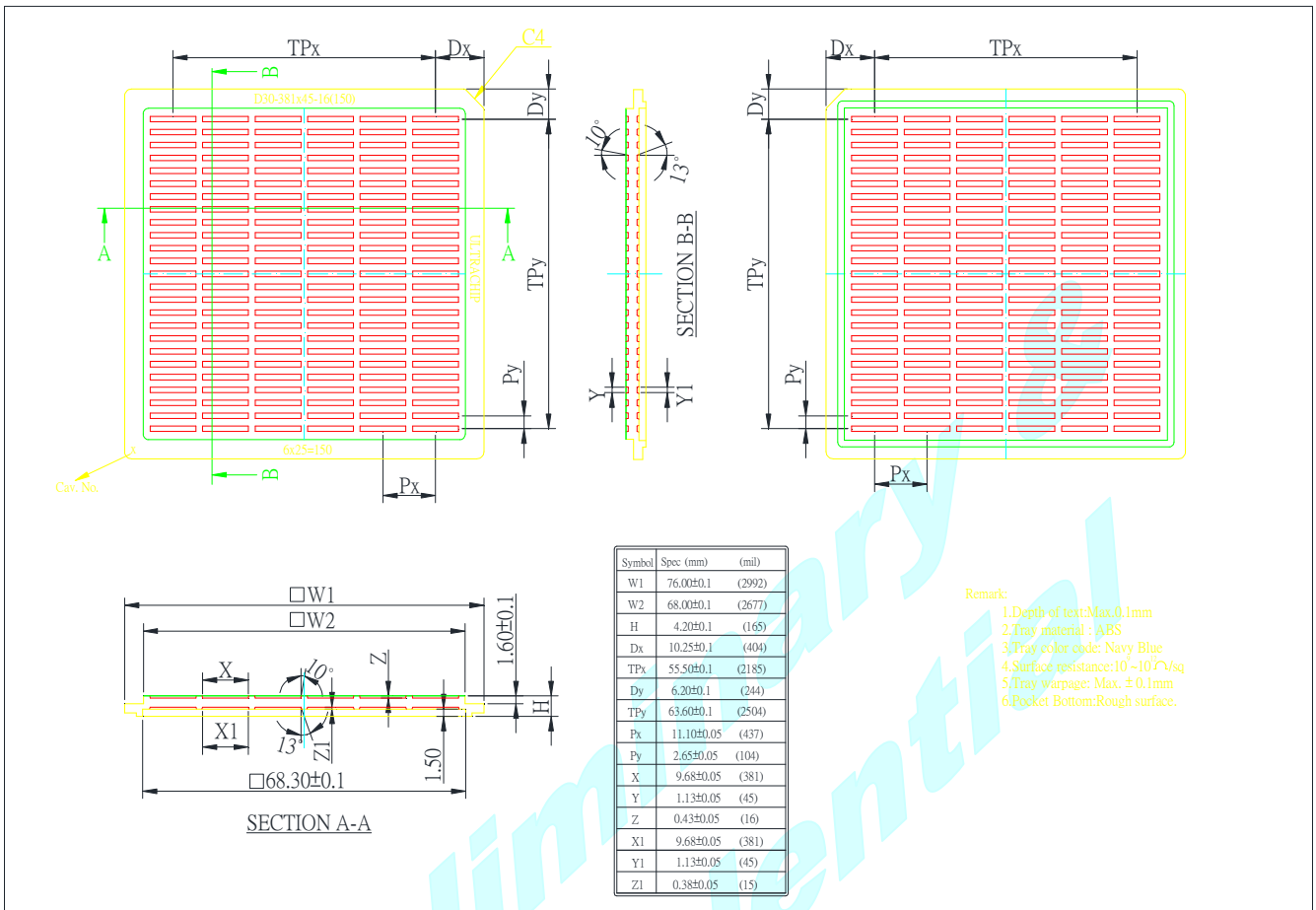

REVISION HISTORY

Revision	Contents	Date
	(N/A)	

*Preliminary &
Confidential*